



Quick Start Guide

Guide de démarrage rapide | Guía de inicio rápido



IMPORTANT | IMPORTANT | IMPORTANTE

Give doorhanger directly to pool owner or hang on door

Donner l'affichette de porte directement au propriétaire de la piscine ou l'accrocher sur la porte

Entregue el gancho para la puerta directamente al propietario de la piscina o cuélguelo en la puerta



How It Works Comment cela fonctionne-t-il? | Cómo funciona



Interface

Votre routeur Internet
Su enrutador de Internet

Internet User Account

FR Internet User Account
SP Internet User Account

Your Internet Router

Votre routeur Internet
Su enrutador de Internet

iAquaLink Web Connect Device

Appareil de connexion Web iAquaLink
Dispositivo de conexión a Internet iAquaLink

Aqualink® Power Center

Bloc d'alimentation Aqualink
Alimentación eléctrica Aqualink

Pools System

Système pour piscine
Sistema para piscinas

1-2-3 Installation Installation 1-2-3 | Instalación 1-2-3

1. Network the iAquaLink device

Se connecter Brancher l'iAquaLink à son bloc d'alimentation

Conexión Conecte iAquaLink al tablero de alimentación eléctrica de iAquaLink

2. Install the iAquaLink device to the power center

Configurer Intégration de l'appareil dans le réseau du client

Configuración Incorporación del dispositivo en la red del consumidor

3. Create a user account at iAquaLink.com, log in and begin enjoying iAquaLink

Configurer votre nom d'utilisateur et mot de passe au www.iAquaLink.com

Configure el nombre de usuario y la contraseña en www.iAquaLink.com

WARNING / AVERTISSEMENT / ADVERTENCIA

FOR YOUR SAFETY - This product must be installed and serviced by a contractor who is licensed and qualified in pool equipment by the jurisdiction in which the product will be installed where such state or local requirements exist, the maintainer must be a professional with sufficient experience in pool equipment installation and maintenance so that all of the instructions in this manual can be followed exactly. Before installing this product, read and follow all warning notices and instructions that accompany this product. Failure to follow warning notices and instructions may result in property damage, personal injury, or death. Improper installation and/or operation will void the warranty. Improper installation and/or operation can create unwanted electrical hazard which can cause serious injury, property damage, or death. Turn off power at the main circuit feeding the Aqualink power center to disconnect the power center from the system.

POUR VOTRE SÉCURITÉ - ce produit doit être pris en charge par une entreprise qui est autorisée et qualifiée pour la réparation des équipements de piscine par la juridiction où le dit produit est installé lorsque de telles exigences locales ou provinciales sont édictées, la personne responsable de l'entretien doit être un professionnel avec une expérience suffisante dans l'installation et l'entretien d'équipement de piscine pour suivre exactement les instructions contenues dans ce guide. Avant d'installer ce produit, lisez et respectez toutes les consignes de mise en garde et les instructions incluses avec ce produit. Le non-respect des avertissements et des instructions pourrait résulter en des dommages matériels, des blessures graves ou même la mort. L'installation ou l'utilisation inappropriée annulera la garantie. L'installation ou l'utilisation inappropriée peuvent créer un danger électrique indésirable qui peut provoquer des blessures graves, des dommages à la propriété ou la mort. Coupez l'électricité au niveau de l'alimentation principale de l'Aqualink pour débrancher le tableau d'alimentation du système.

PARA SU SEGURIDAD - Este producto se debe ser instalado y mantenido por un contratista que sea autorizado y calificado en el equipo de la piscina por la jurisdicción en la cual el producto será instalado donde existen requisitos estatales o locales. En el caso que ningún requisito del estado o local exista, el instalador o el personal de mantenimiento debe ser un profesional con suficiente experiencia en la instalación y el mantenimiento de equipo de piscina para poder seguir todas las instrucciones de este manual exactamente. Antes de instalar este producto, lea y siga todos los avisos e instrucciones que acompañan este producto. La falta de seguir avisos e instrucciones puede dar lugar a daños materiales, a daños corporales, o a muerte. La incorrecta instalación y/o la operación anularán la garantía. La incorrecta instalación y/o la operación pueden crear el peligro eléctrico indeseado que puede causar lesión, daños materiales, o muerte. Apague la energía eléctrica en el circuito principal que alimenta el centro de control Aqualink para desconectar el centro de control del sistema.

CAUTION / MISE EN GARDE / PRECAUCIÓN

If replacing the CPU board go to Clear Memory in the System Setup menu and clear the memory. To avoid damages caused by static electricity, handle the PCB by its edges only. Avoid touching any electronics components with your fingertips. Do not replace the PCB in the rain.

Pour éviter des dommages causés par l'électricité statique, manipuler uniquement la carte de circuit imprimé par les extrémités. Éviter de toucher les composants électroniques avec vos doigts. Ne pas remplacer la carte de circuit imprimé sous la pluie.

Para evitar los daños causados por la electricidad estática, manipule el PCB sosteniéndolo únicamente por sus bordes. Evite tocar cualquier componente electrónico con las puntas de los dedos. No cambie el PCB bajo la lluvia.

Installation manual (H0364100) and owners manual (H0364200), available online at www.iAquaLink.com or by calling: USA: 1-800-822-7933 | Canada: 1-888-647-4004 | Australia 1800.688.552

Manuel d'installation complet (H0364100) et Manuel du propriétaire (H0364200), disponible en ligne au www.iAquaLink.com ou en appelant au: USA: 1-800-822-7933 | Canada: 1-888-647-4004 | Australia 1800.688.552

El Manual de Instalación (H0364100) y el Manual del Usuario (H0364200), están disponibles en la página web www.iAquaLink.com o llamando: USA: 1-800-822-7933 | Canada: 1-888-647-4004 | Australia 1800.688.552

1 Network the iAquaLink Device Go to step 1.1 or 1.2

FR Network the iAquaLink Device Go to step 1.1 or 1.2 | SP Network the iAquaLink Device Go to step 1.1 or 1.2

1.1 WiFi Network Connection Option | Sans fil — configuration à l'aide d'un ordinateur | Inalámbrica, configuración mediante computadora

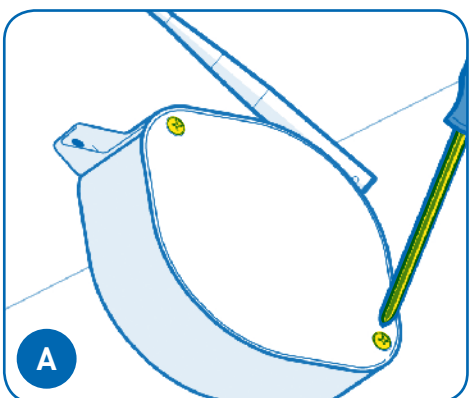

Remove the device lid by removing the two screws.

Retirer le couvercle de l'appareil en enlevant les deux vis.

Retire la tapa del dispositivo al quitar los dos tornillos.

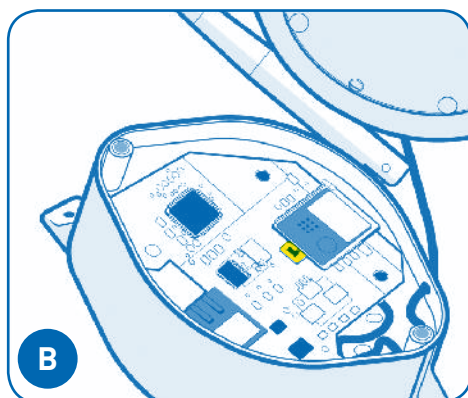

Locate the WiFi/WIRED switch and ensure it is in the WiFi position.

Localiser l'interrupteur WI-FI/WIRED et s'assurer qu'il est à la position WI-FI.

Ubique el interruptor WI-FI/WIRED (inalámbrico/por cable) y asegúrese de que esté en la posición WI-FI (inalámbrico).

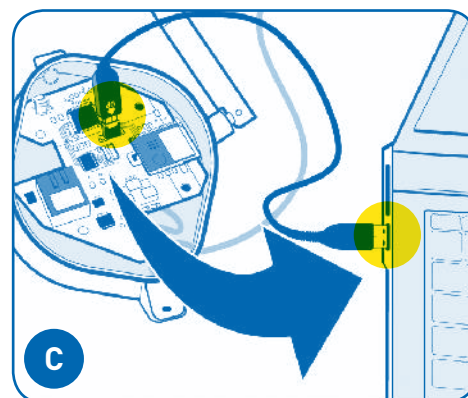

Attach the iAquaLink device to an internet connected PC or Mac® with a USB cable.

Attach the iAquaLink device to an internet connected PC or Mac® with a USB cable.

Attach the iAquaLink device to an internet connected PC or Mac® with a USB cable.

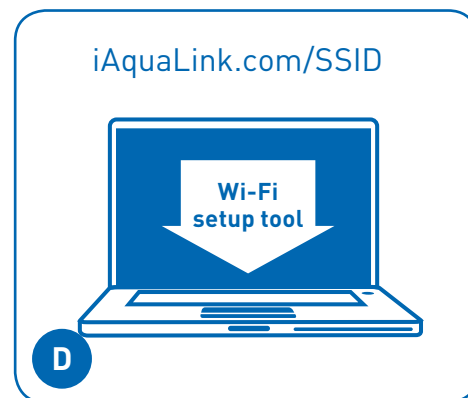

With a web browser, download & run the WiFi setup tool from iAquaLink.com/SSID

With a web browser download & run the WiFi setup tool from iAquaLink.com/SSID

With a web browser download & run the WiFi setup tool from iAquaLink.com/SSID

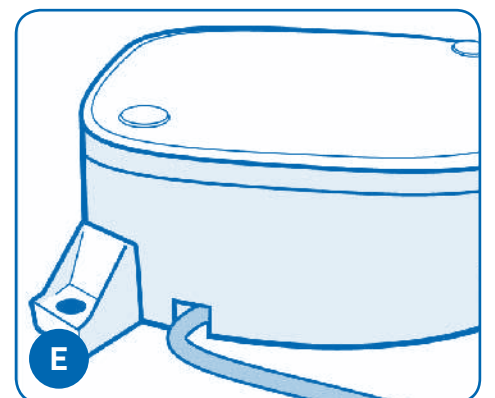

After programming the device with the network SSID & Key, replace the rubber gasket & cover.

After programming the device with the network SSID & Key, replace the rubber gasket & cover.

After programming the device with the network SSID & Key, replace the rubber gasket & cover.

i Helpful hints | Conseils pratiques | Consejos útiles



Wi-Fi installs only

- MS Windows only: close any popup windows that open after connecting the iAquaLink device to the computer (step 1.1-C)
- A security warning may pop up. Ignore it and proceed.
- After step 1.1-D (above), the setup tool should indicate successful programming of the iAquaLink. If not, repeat steps 1.1-C and 1.1-D.

Wi-Fi installe uniquement

- MS Windows only: close any popup windows that open after connecting the iAquaLink device to the computer (step 1.1-C)
- A security warning may pop up. Ignore it and proceed.
- After step 1.1-D (above), the tool should indicate successful programming of the iAquaLink. If not, repeat steps 1.1-C and 1.1-D.

Wi-Fi se instala únicamente

- MS Windows only: close any popup windows that open after connecting the iAquaLink device to the computer (step 1.1-C)
- A security warning may pop up. Ignore it and proceed.
- After step D (above), the tool should indicate successful programming of the iAquaLink. If not, repeat steps 1.1-C and 1.1-D.



Wi-Fi installs only

The iAquaLink device uses Wi-Fi standard 802.11b for maximum range and broadest compatibility with most residential Wi-Fi routers and wireless access points. Some Wi-Fi routers or access points may require "b" mode be enabled in order to communicate with the iAquaLink Device. Every router is different - please see router instructions for help.

Wi-Fi installe uniquement

The iAquaLink device uses Wi-Fi standard 802.11b for maximum range and broadest compatibility with most residential Wi-Fi routers and wireless access points. Some Wi-Fi routers or access points may require "b" mode be enabled in order to communicate with the iAquaLink Device. Every router is different - please see router instructions for help.

Wi-Fi se instala únicamente

The iAquaLink device uses Wi-Fi standard 802.11b for maximum range and broadest compatibility with most residential Wi-Fi routers and wireless access points. Some Wi-Fi routers or access points may require "b" mode be enabled in order to communicate with the iAquaLink Device. Every router is different - please see router instructions for help.

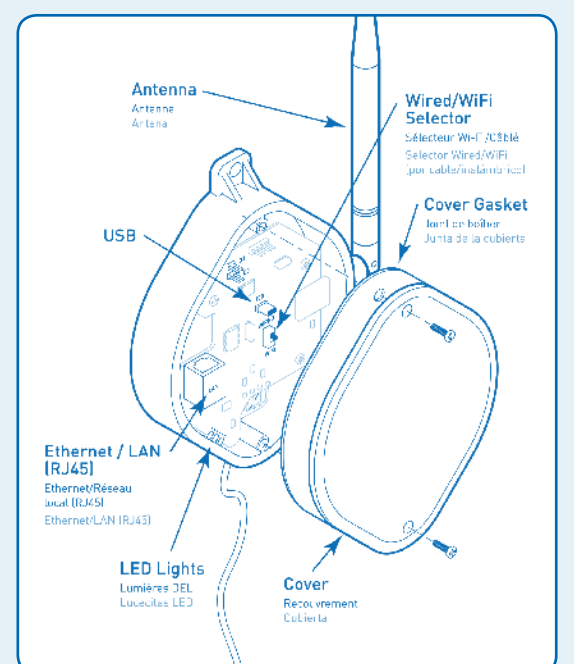

1.2 Wired (Ethernet) Network Connection Option | FR Wired (Ethernet) Network Connection | SP Wired (Ethernet) Network Connection

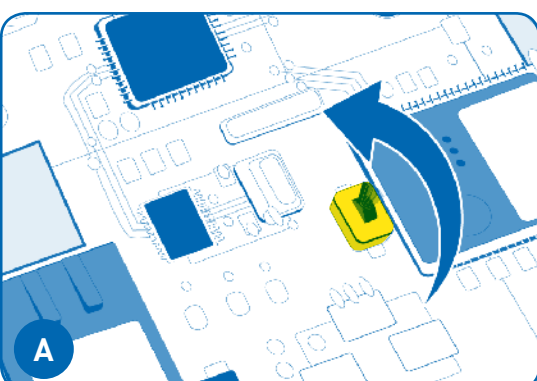

Remove the device lid by removing the two screws. Locate the WiFi/WIRED switch and ensure it is in the WIRED position.

Retirer le couvercle de l'appareil en enlevant les deux vis. Localiser l'interrupteur WI-FI/WIRED et s'assurer qu'il est à la position WIRED.

Retire la tapa del dispositivo al quitar los dos tornillos. Ubique el interruptor WI-FI/WIRED (inalámbrico/por cable) y asegúrese de que esté en la posición WIRED (por cable).

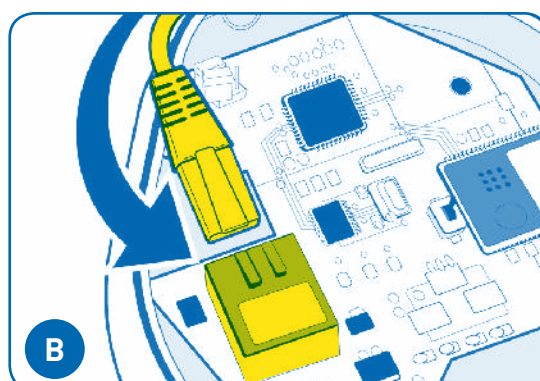

Using an Ethernet cable, connect the device to the home network's router.

À l'aide d'un câble Ethernet standard, brancher l'une des extrémités du câble au raccord sur le panneau de l'appareil. Connecter l'autre extrémité au routeur de réseau domestique.

Con el cable de Ethernet estándar, conecte un extremo del cable al conector del tablero de dispositivo. Conecte el otro extremo al enrutador de red local.

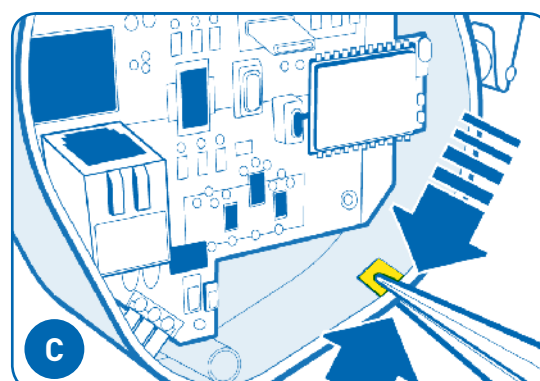

Remove device lid and gasket by removing the two screws.

Pour permettre au câble de sortir de l'appareil, empoigner la partie détachable et effectuer un mouvement de va-et-vient jusqu'à ce qu'elle cède.

Para permitir que el cable salga del dispositivo, sujete la pieza separable y muévela hacia adelante y atrás hasta que se quiebre.

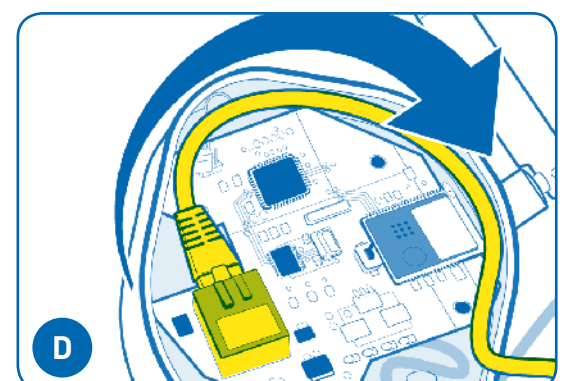

Wrap the cable as shown inside the device and use the break-away as an exit hole. Replace the rubber gasket & cover.

Enrouler le câble comme illustré à l'intérieur de l'appareil, puis utiliser la partie détachée comme trou de sortie. Repositionner le boîtier d'étanchéité et les deux vis.

Enrolle el cable como se muestra dentro del dispositivo y utilice la separación como orificio de salida. Vuelva a colocar la cubierta de la junta y los dos tornillos.

2 Install the iAquaLink Device Pictures are for general guidance—some power centers may look different.

FR Install the iAquaLink Device Pictures are for general guidance—some power centers may look different. | SP Install the iAquaLink Device Pictures are for general guidance—some power centers may look different.

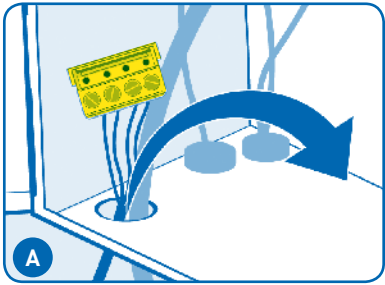

All power to the power center must be OFF! Route the 4-wire cable through the bottom access hole into the low-voltage raceway. The red 4-wire connector may not be required for all installations.

FR All power to the power center must be OFF! Route the 4-wire cable through the bottom access hole and low-voltage raceway. The red 4-pin connector may need to be removed first.

SP All power to the power center must be OFF! Route the 4-wire cable through the bottom access hole and low-voltage raceway. The red 4-pin connector may need to be removed first.

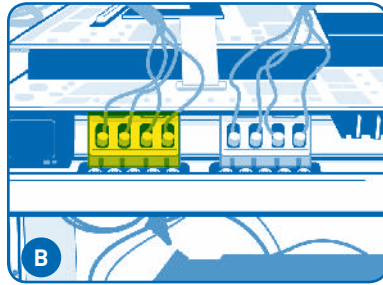

Route the 4-wire cable toward the red 4-wire connector.

FR Route the 4-wire cable toward the red 4-Pin socket.

SP Route the 4-wire cable toward the red 4-Pin socket.

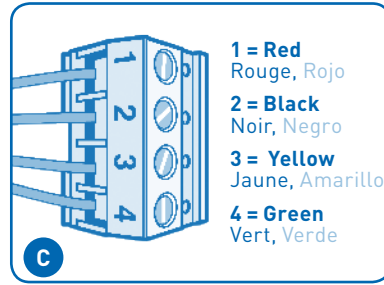

1 = Red
Rouge, Rojo
2 = Black
Noir, Negro
3 = Yellow
Jaune, Amarillo
4 = Green
Vert, Verde

Ensure that all wires are properly attached to the red 4-wire connector. Some connectors may look different.

S'assurer que tous les câbles sont correctement reliés au connecteur rouge à 4 broches.

Asegúrese de que todos los cables estén correctamente conectados al conector rojo de 4 clavijas.

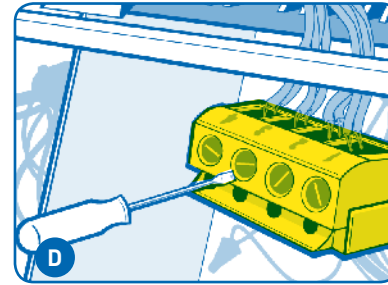

Up to two devices can be connected to each 4-wire connector (two wires per hole). If more capacity is needed, a 6584 multiplex board can be installed. See "helpful hints" section.

La prise à 4 broches peut relier jusqu'à 2 appareils (deux câbles par trou). En cas de besoin, un panneau multiplexé 6584 peut être installé. Voir la section « Conseils pratiques ».

Pueden conectarse hasta dos dispositivos a un enchufe de 4 clavijas (dos cables por orificio). Si se necesita más capacidad, se puede instalar un tablero multiplex 6584. Consulte la sección "sugerencias prácticas".

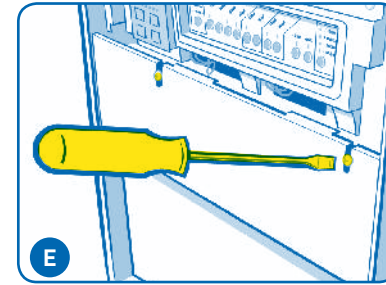

Reassemble the power center, making sure no wires are pinched. Replace all panels or screws before returning electrical power to the power center.

FR Reassemble the power center, making sure no wires are pinched. Replace all panels or screws before returning electrical power to the power center.

SP Reassemble the power center, making sure no wires are pinched. Replace all panels or screws before returning electrical power to the power center.



Ensure all LED's (Red, Amber, & Green) are illuminated before proceeding to step 3.

FR Ensure all LED's (Red, Amber, & Green) are illuminated before proceeding to step 3.

SP Ensure all LED's (Red, Amber, & Green) are illuminated before proceeding to step 3.

i Helpful hints | Conseils pratiques | Consejos útiles

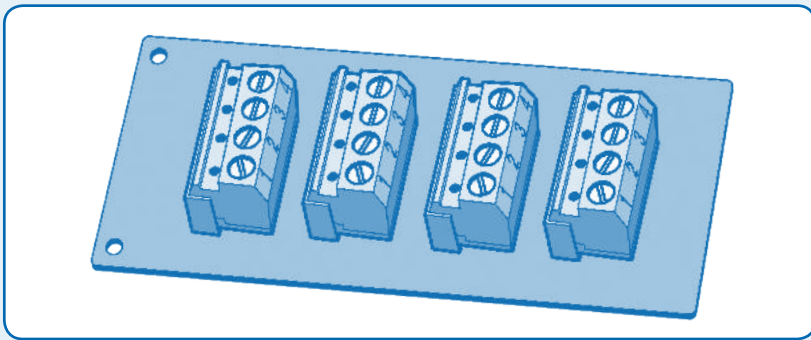

When and how to use a 6584 multiplex board

If you have more than two sets of wires that need to be connected to the red four pin connectors, install a 6584 Multiplex board. For installation instructions see instruction sheet included with 6584.

Quand et comment utiliser un panneau multiplexé 6584

Si vous possédez des jeux de câbles supplémentaires à relier aux connecteurs à 4 broches rouges, installez un panneau multiplexé 6584. Pour les instructions d'installation, consulter la feuille de consignes fournie.

Cuándo y cómo utilizar un tablero multiplex 6584

Si tiene conjuntos de cables adicionales que deben conectarse a conectores rojos de cuatro clavijas, instale un tablero multiplex 6584. Para conocer las instrucciones de instalación, consulte la hoja de instrucciones incluida.



What the LEDs mean

Red = Power
Yellow = Connected to Network
Green = Connected to Internet
LED's may flicker—this is normal.

Que signifient les DEL

Rouge = Alimentation
Jaune = Connecté au réseau
Vert = Connecté à l'Internet

Qué significan los LED

Rojo = Encendido
Amarillo = Conectado a la red
Verde = Conectado a Internet

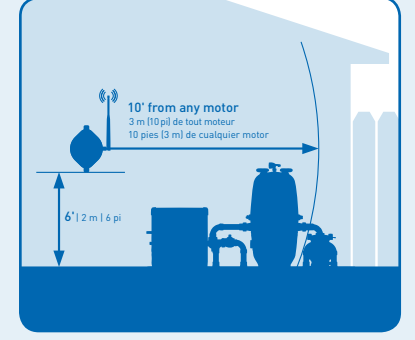

For best performance (Wi-Fi installs only)

- Attach the Web Connect Device as close to the home's router as possible
- Mount the antenna at least 6 ft. (2m) high and 10 ft. (3m) from any electric motor, device, or metal object
- Always mount the iAquaLink device with the antenna on the right side, pointing up toward the sky.

Installation sans fil seulement (Wi-Fi installs only)

- Placer l'appareil de connexion à Internet aussi près du routeur domestique que possible
- Monter l'antenne à une distance d'au moins 2 m (6 pi) de haut et à 3 m (10 pi) de tout moteur électrique, appareil ou objet métallique.
- FRENCH

Instalaciones inalámbricas únicamente (Wi-Fi installs only)

- Conecte el Dispositivo de conexión a Internet lo más cerca posible del enrutador local
- Monte la antena por lo menos a 6 pies (2 m) de altura y a 10 pies (3 m) de cualquier motor eléctrico, dispositivo u objeto de metal
- SPANISH

3 Create & Setup Account

Créez et configurez le compte | Cree y configure la cuenta

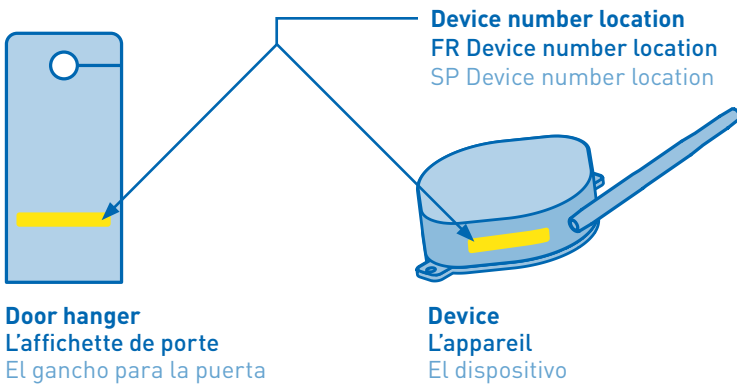

Door hanger
L'affichette de porte
El gancho para la puerta

Device
L'appareil
El dispositivo

- Before starting, find the iAquaLink 12 digit Device number found on the device or door hanger. The number starts with "Q" & looks like: QXX-XXX-XXX-XXX
- On the same network the iAquaLink device is connected to, use a computer to go to iAqualink.com
- Click the link to sign-up & create a user account. If user already has an account, skip to step 3E - "add location"
- Follow the directions to create the user account, then proceed to Sign-in to the account
- Click the "Add Location" button to add the device into the user account. You can now use iAquaLink

- FR Before starting, find the iAquaLink 12 digit Device number found on the device or door hanger. Starts with "Q" & looks like: QXX-XXX-XXX-XXX
- FR Through the same network the iAquaLink device is connected to, using a computer go to iAqualink.com
- FR If user has an account, have them sign-in, then proceed to step 3E - "add location". Otherwise, find the Link to sign-up & create a new user account
- FR Follow the directions to create the user account, then proceed to Sign-in to the account
- FR Click the "Add Location" button to add the device into the user account. You can now use iAquaLink

- SP Before starting, find the iAquaLink 12 digit Device number found on the device or door hanger. Starts with "Q" & looks like: QXX-XXX-XXX-XXX
- SP Through the same network the iAquaLink device is connected to, using a computer go to iAqualink.com
- SP If user has an account, have them sign-in, then proceed to step 3E - "add location". Otherwise, find the Link to sign-up & create a new user account
- SP Follow the directions to create the user account, then proceed to Sign-in to the account
- SP Click the "Add Location" button to add the device into the user account. You can now use iAquaLink

3.1 Download the Free App (optional)

Télécharger l'application libre (optional) | Descargue la aplicación gratis (optional)



- iPhone®/iPad®/iPod Touch® app available on iTunes®; search for "iAquaLink"
- Android app available from Google Play; search for "iAquaLink"
- A mobile web app may be used with most other smart devices. Go to: iAquaLink.com/mobile

- L'application iPhone/iPad/iPod Touch est disponible sur iTunes; Chercher « iAquaLink »
- L'application Android est disponible sur l'Android Market; Chercher « iAquaLink »
- Une application Web par navigateur pour les appareils mobiles est également disponible au www.iAquaLink.com/mobile

- Aplicaciones para iPhone/iPad/iPod Touch disponibles en iTunes; simplemente busque "iAquaLink"
- Aplicación para Android disponible en Android Market; busque "iAquaLink"
- También hay disponible una aplicación web basada en navegador para dispositivos móviles en www.iAquaLink.com/mobile



www.iAquaLink.com

i Helpful hints | Conseils pratiques | Consejos útiles



Wi-Fi installs only

- All the LED's (Red, Amber, & Green) must all be lit on the iAquaLink device before proceeding to step 3.
- For security reasons, the account server only allows a Location (iAquaLink device) to be added to an iAquaLink account when the accessing computer is logged into the same network as the iAquaLink device being added.

Wi-Fi installe uniquement

- Tous les LED (rouge, orange, et vert) doivent tous être allumés sur le périphérique iAquaLink pour effectuer l'étape 3.
- Pour des raisons de sécurité, le serveur de compte ne permet qu'une Lieu (Dispositif iAquaLink) à ajouter lorsque l'appareil est connecté au serveur via le même réseau que l'ordinateur de configuration.

Wi-Fi se instala únicamente

- Todos los LED (rojo, ámbar, y verde) todo debe estar encendido en el dispositivo iAquaLink para llevar a cabo el paso 3.
- Por razones de seguridad, el servidor cuenta sólo permite una posición (Dispositivo iAquaLink) que se añade cuando el dispositivo está conectado al servidor a través de la misma red que el ordenador de configuración.