



Installation Manual



AquaLink[®] RS

All Button and OneTouch[™] Control Systems



For use with Pool/Spa Combination,
Pool Only/Spa Only, and Dual Equipment
AquaLink[®] RS Systems with Rev O.2 Firmware

WARNING

FOR YOUR SAFETY - This product must be installed and serviced by a professional pool/spa service technician. The procedures in this manual must be followed exactly. Failure to follow warning notices and instructions may result in property damage, serious injury, or death. Improper installation and/or operation will void the warranty.

Table of Contents

<p>Section 1. Important Safety Instructions4</p> <p>Section 2. System Overview6</p> <p>2.1 Package Contents 6</p> <p>2.2 System Component Specifications and Dimensions 7</p> <p>2.3 Basic Plumbing 8</p> <p>Section 3. Installation10</p> <p>3.1 Power Center Mounting 10</p> <p>3.2 High Voltage Wiring 10</p> <p>3.3 Low Voltage Wiring 16</p> <p>3.4 Heater Connection 19</p> <p>3.5 Temperature Sensors 22</p> <p>3.6 Jandy Valve Actuators 22</p> <p>3.7 Auxiliary Power Centers 22</p> <p>3.8 All Button Control Panel Installation 23</p> <p>3.9 OneTouch™ Control Panel Installation 24</p> <p>3.10 Wireless OneTouch™ Control Panel Installation 26</p> <p>Section 4. System Startup28</p> <p>4.1 All Button Programming 28</p> <p>4.2 All Button Reset and Display Messages 30</p> <p>4.3 OneTouch™ Programming 30</p> <p>4.4 OneTouch™ Reset and Display Messages 32</p> <p>4.5 Variable Speed Pump Menu 32</p> <p>4.6 All Button and OneTouch™ System Defaults and General Modes 36</p> <p>4.7 All Button Menu Flow Chart 38</p> <p>4.8 OneTouch™ Menu Flow Chart 39</p>	<p>Section 5. Troubleshooting40</p> <p>5.1 All Button and OneTouch™ Quick Troubleshooting Guide 40</p> <p>5.2 Wireless OneTouch™ Quick Troubleshooting Guide 41</p> <p>Section 6. Power Center Wiring Diagram for Combos and Onlys43</p> <p>Section 7. Power Center PCB DIP Switch Settings44</p> <p>7.1 DIP Switch Functions 44</p> <p>7.2 DIP Switch Settings for Pool and Spa Combination 45</p> <p>7.3 DIP Switch Settings for Pool or Spa Only 46</p> <p>7.4 DIP Switch Settings for Heat Pump Installation 46</p> <p>Section 8. General, Water Feature and Light Aux Labels47</p>
---	---

EQUIPMENT INFORMATION RECORD	
DATE OF INSTALLATION _____	
INSTALLER INFORMATION _____	
INITIAL PRESSURE GAUGE READING (WITH CLEAN FILTER) _____	
PUMP MODEL _____	HORSEPOWER _____
FILTER MODEL _____	SERIAL NUMBER _____
CONTROL PANEL MODEL _____	SERIAL NUMBER _____
NOTES: _____	

Section 1. Important Safety Instructions

READ AND FOLLOW ALL INSTRUCTIONS

Lire la notice technique.

All electrical work must be performed by a licensed electrician and conform to all national, state, and local codes. When installing and using this electrical equipment, basic safety precautions should always be followed, including the following:

DANGER

To reduce the risk of injury, do not remove the suction fittings of your spa or hot tub. Never operate a spa or hot tub if the suction fittings are broken or missing. Never replace a suction fitting with one rated less than the flow rate marked on the equipment assembly.

WARNING

Prolonged immersion in hot water may induce hyperthermia. Hyperthermia occurs when the internal temperature of the body reaches a level several degrees above the normal body temperature of 98.6°F (37°C). The symptoms of hyperthermia include dizziness, fainting, drowsiness, lethargy, and an increase in the internal temperature of the body. The effects of hyperthermia include: 1) unawareness of impending danger; 2) failure to perceive heat; 3) failure to recognize the need to exit spa; 4) physical inability to exit spa; 5) fetal damage in pregnant women; 6) unconsciousness resulting in a danger of drowning.

WARNING

To Reduce the Risk of Injury -

- a) The water in a spa should never exceed 104°F (40°C). Water temperatures between 100°F (38°C) and 104°F (40°C) are considered safe for a healthy adult. Lower water temperatures are recommended for young children and when spa use exceeds 10 minutes.
- b) Since excessive water temperatures have a high potential for causing fetal damage during the early months of pregnancy, pregnant or possibly pregnant women should limit spa water temperatures to 100°F (38°C).
- c) Before entering a spa or hot tub, the user should measure the water temperature with an accurate thermometer since the tolerance of water temperature-regulating devices varies.
- d) The use of alcohol, drugs, or medication before or during spa or hot tub use may lead to unconsciousness with the possibility of drowning.
- e) Obese persons and persons with a history of heart disease, low or high blood pressure, circulatory system problems, or diabetes should consult a physician before using a spa.
- f) Persons using medication should consult a physician before using a spa or hot tub since some medication may induce drowsiness while other medication may affect heart rate, blood pressure, and circulation.

WARNING

Risk of electric shock - Install the power center at least five (5) feet (1.52m) from the inside wall of the pool and/or hot tub using non-metallic plumbing. Canadian installations must be at least three (3) meters (10 feet) from the water.

Children should not use spas or hot tubs without adult supervision.

Do not use spas or hot tubs unless all suction guards are installed to prevent body and hair entrapment.

People using medications and/or having an adverse medical history should consult a physician before using a spa or hot tub.

AVERTISSEMENT

Danger d'électrocution - Les installations Canadiennes doivent se trouver à au moins trois (3) mètres de l'eau.

Ne pas laisser les enfants utiliser une cuve de relaxation sans surveillance.

Pour éviter que les cheveux ou une partie du corps puissent être aspirés, ne pas utiliser une cuve de relaxation si les grilles de prise d'aspiration ne sont pas toutes en place.

Les personnes qui prennent des médicaments ou ont des problèmes de santé devraient consulter un médecin avant d'utiliser une cuve de relaxation.

⚠ WARNING

People with infectious diseases should not use a spa or hot tub.
 To avoid injury, exercise care when entering or exiting the spa or hot tub.
 Do not use drugs or alcohol before or during the use of a spa or hot tub to avoid unconsciousness and possible drowning.
 Pregnant or possibly pregnant women should consult a physician before using a spa or hot tub.
 Water temperature in excess of 100°F (38°C) may be injurious to your health.
 Before entering a spa or hot tub measure the water temperature with an accurate thermometer.
 Do not use a spa or hot tub immediately following strenuous exercise.
 Prolonged immersion in a spa or hot tub may be injurious to your health.
 Do not permit any electric appliance (such as a light, telephone, radio, or television) within 5 feet (1.52m) of a spa or hot tub.
 The use of alcohol, drugs or medication can greatly increase the risk of fatal hyperthermia in hot tubs and spas.
 Water temperature in excess of 100°F (38°C) may be hazardous to your health.

⚠ AVERTISSEMENT

Les personnes atteintes de maladies infectieuses ne devraient pas utiliser une cuve de relaxation.
 Pour éviter des blessures, user de prudence en entrant dans une cuve de relaxation et en sortant.
 Pour éviter l'évanouissement et la noyade éventuelle, ne prendre ni drogue ni alcool avant d'utiliser une cuve de relaxation ni quand on s'y trouve.
 Les femmes enceintes, que leur grossesse soit confirmée ou non, devraient consulter un médecin avant d'utiliser une cuve de relaxation.
 Il peut être dangereux pour la santé de se plonger dans de l'eau à plus de 38°C (100°F).
 Avant d'utiliser une cuve de relaxation mesurer la température de l'eau à l'aide d'un thermomètre précis.
 Ne pas utiliser une cuve de relaxation immédiatement après un exercice fatigant.
 L'utilisation prolongée d'une cuve de relaxation peut être dangereuse pour la santé.
 Ne pas placer d'appareil électrique (luminaire, téléphone, radio, téléviseur, etc) à moins de 1.52m de cette cuve de relaxation.
 La consommation d'alcool ou de drogue augmente considérablement les risques d'hyperthermie mortelle dans une cuve de relaxation.
 Il peut être dangereux pour la santé de se plonger dans de l'eau à plus de 38°C (100°F).

⚠ WARNING

To avoid injury ensure that you use this control system to control only packaged pool/spa heaters which have built-in operating and high limit controls to limit water temperature for pool/spa applications. This device should not be relied upon as a safety limit control.

⚠ CAUTION

A terminal bar marked "GROUND" is provided within the power center. To reduce the risk of electrical shock, connect this terminal bar to the grounding terminal of your electric service or supply panel with a continuous copper conductor having green insulation and one that is equivalent in size to the circuit conductors supplying this equipment, but no smaller than no. 12 AWG (3.3mm). In addition, a second wire connector should be bonded with a no. 8 AWG (4.115mm) copper wire to any metal ladders, water pipes, or other metal within five (5) feet (1.52m) of the pool/spa.

⚠ CAUTION

A ground-fault circuit-interrupter must be provided if this device is used to control underwater lighting fixtures. The conductors on the load side of the ground-fault circuit-interrupter shall not occupy conduit, boxes, or enclosures containing other conductors unless the additional conductors are also protected by a ground-fault circuit-interrupter. Refer to local codes for complete details.









Attention installer: Install to provide drainage of compartment for electrical components.

SAVE THESE INSTRUCTIONS

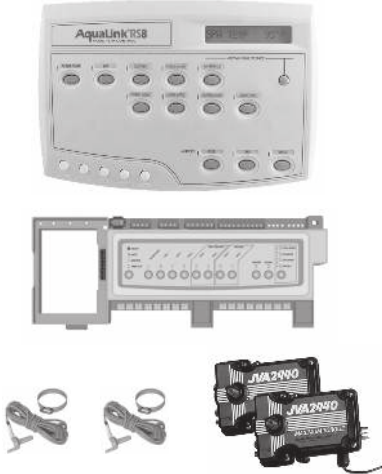
Section 2. System Overview

2.1 Package Contents

Package contents will depend on which AquaLink® RS System you are installing. All Jandy AquaLink® RS Systems come complete with the appropriate number of 3HP relays needed.

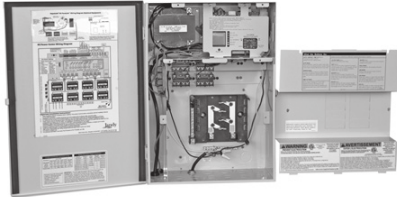
Control System Sub-Assemblies		
All Button	OneTouch™	Wireless OneTouch
 <p>All Button Control Panel, Power Center PCB, Two (2) Temp Sensors, Required number of Relays, Two (2) JVA's (Pool/Spa Combo Systems)</p>	 <p>OneTouch Control Panel, Power Center PCB, Two (2) Temp Sensors, Required number of Relays, Two (2) JVA's (Pool/Spa Combo Systems)</p>	 <p>Wireless OneTouch Control Panel, Outdoor Transceiver J-box, Power Center PCB, Two (2) Temp Sensors, Required number of Relays, Two (2) JVA's</p>
Power Centers		
 <p>Foundation and Standard Power Center (with mounting brackets, transformer and 4 relays)</p>	 <p>PureLink™ Power Center (with mounting brackets, transformer, AquaPure® PCB's, AquaPure® transformer, and 4 3HP relays)</p>	
 <p>Sub-Panel Power Center (with mounting brackets, transformer, breaker mount plate, GFCI knockout, and relays)</p>	 <p>PureLink™ Sub-Panel Power Center (with mounting brackets, transformer, breaker mount plate, GFCI knockout, AquaPure® PCB's, AquaPure® transformer, and 4 3HP relays)</p>	

2.2 System Component Specifications and Dimensions

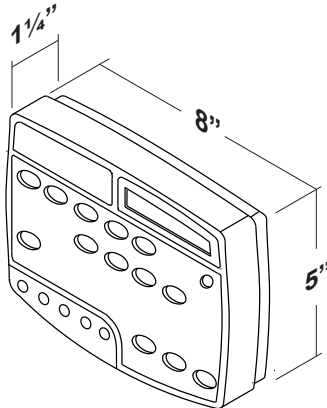
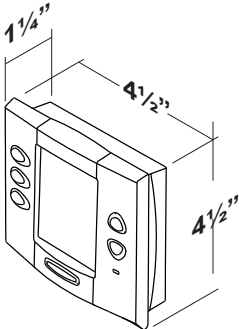
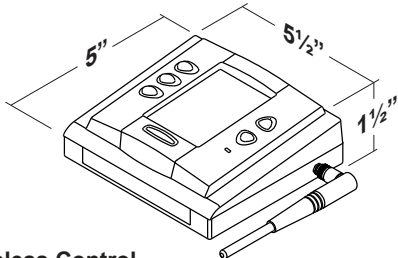
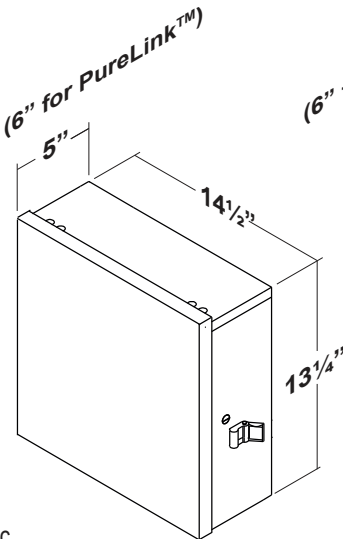
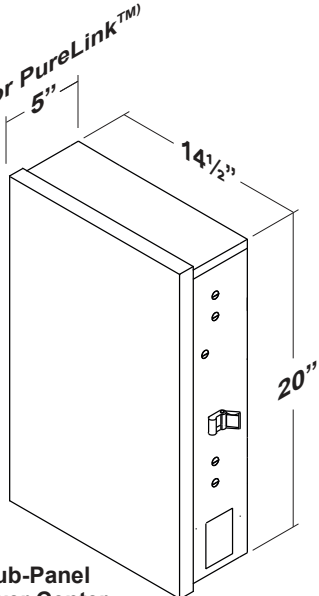
Specifications (USA and Canada)						
Power Supply	120 VAC; 60 Hz; 3 A					
Contact Rating	High voltage - 25 A; 3HP @ 240 VAC 1½ HP @120 VAC 1500 Watts Incandescent					
	Low Voltage - Class 2, 1 A @ 24 VAC					
Service Switch	All Circuits (located at Power Center in Service Mode)					
Specifications (European)						
Power Supply	230-240VAC; 50/60 Hz; 3 A					
Contact Rating	High voltage - 25 A; 3HP @ 240 VAC					
	Low Voltage - Class 2, 1 A @ 24 VAC					
Service Switch	All Circuits (located at Power Center in Service Mode)					
Dimensions						
 <p>All Button Control Panel</p>  <p>One Touch™ Control Panel</p>  <p>Wireless Control Panel</p>  <p>Standard Power Center</p>  <p>Sub-Panel Power Center</p>						
Suitable Listed Breakers (Available Locally)						
Manufacturer	CIRCUIT BREAKER					Filler Plate
	Single	Double	Twin	Quad	GFCB	
Cutler-Hammer® ¹	BR	BR	BR	BQC	GFCB	BRFP
Murray® ²	MP-T	MP-T	MH-T	MH-T	MP-GT	LX100FP
Siemens® ³	QP	QP	QT	QT	QPF	QF3
Square D® ⁴	HOM	HOM	HOMT	HOMT	HOM	HOMFP
Thomas & Betts® ⁵	TB	TB	TBBD	TBBQ	GFB	FP-1C-TB

¹ Cutler-Hammer is a registered trademark of Cutler-Hammer, Inc.

² Murray is a registered trademark of Briggs & Statton Corp.

³ Siemens is a registered trademark of Siemens Energy and Automation, Inc.

⁴ Square D is a registered trademark of Square D Company.

⁵ Thomas & Betts is a registered trademark of Thomas & Betts Corp.

2.3 Basic Plumbing

2.3.1 Plumbing for Pool and Spa Combination

The following plumbing diagrams illustrate simplified versions of standard plumbing setups for a pool and spa that share the same filter pump, filter, and heater. The intake and return JVA's turn simultaneously so when the spa button is pressed on the AquaLink® RS control panel, water circulation switches between pool and spa (consult the *Jandy Valve Actuator Installation and Operation Manual* to ensure that the JVA's are synchronized and rotate properly). Please consult the Jandy Valve Plumbing Manual for further examples of pool/spa plumbing.

For pool only/spa only or dual equipment plumbing, please refer to the Jandy Valve Plumbing Manual for further examples.

NOTE When the filter system is shared (a pool/spa combo), the spa water must be able to overflow back to the pool.

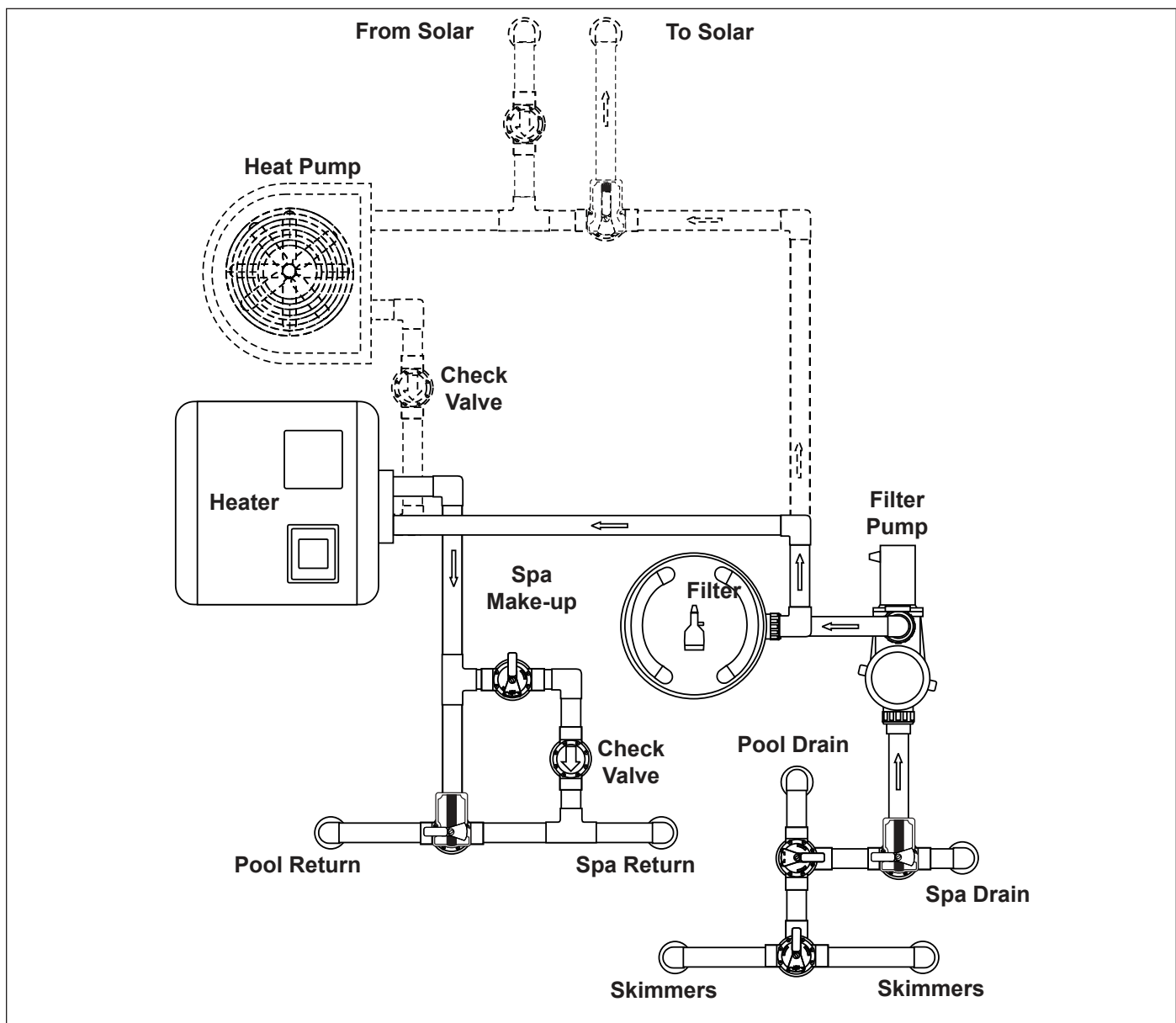

2.3.2 Booster Pump Pool Cleaner Plumbing

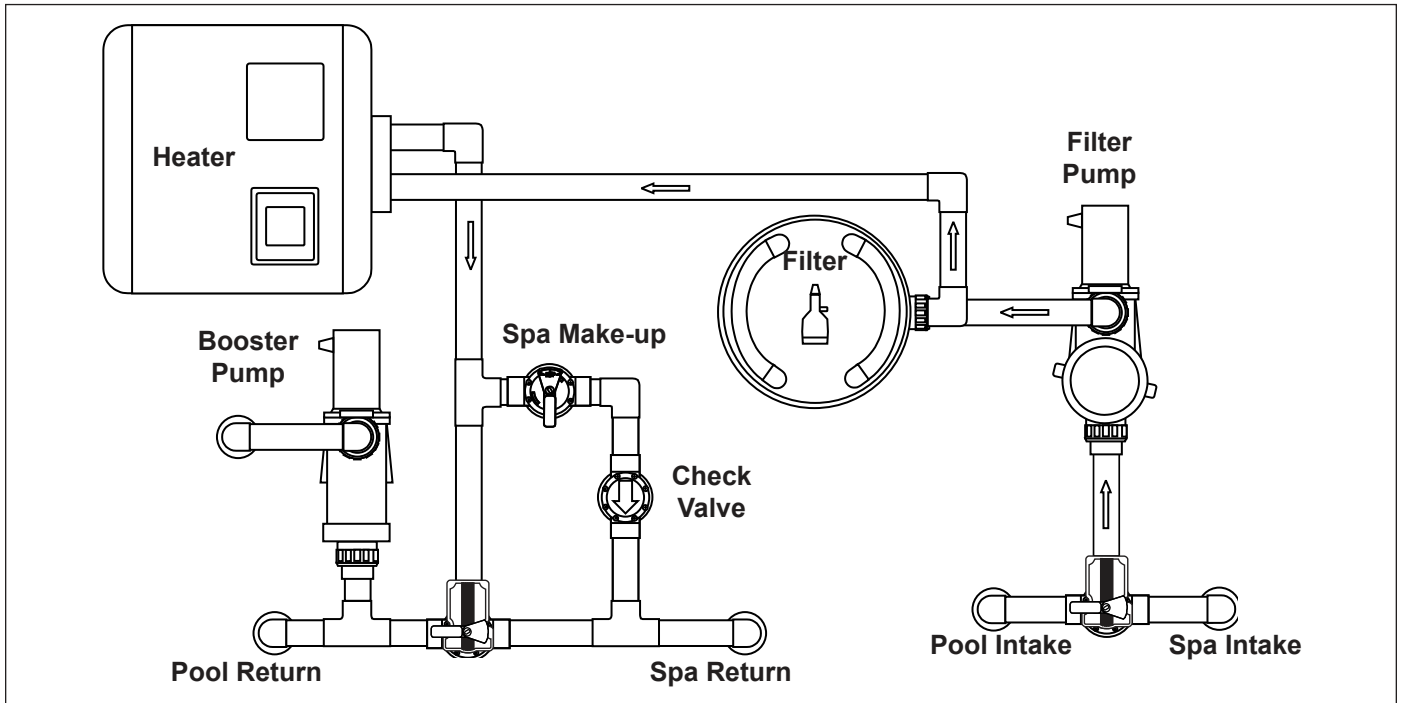

2.3.3 Non-Booster Pump Pool Cleaner Plumbing

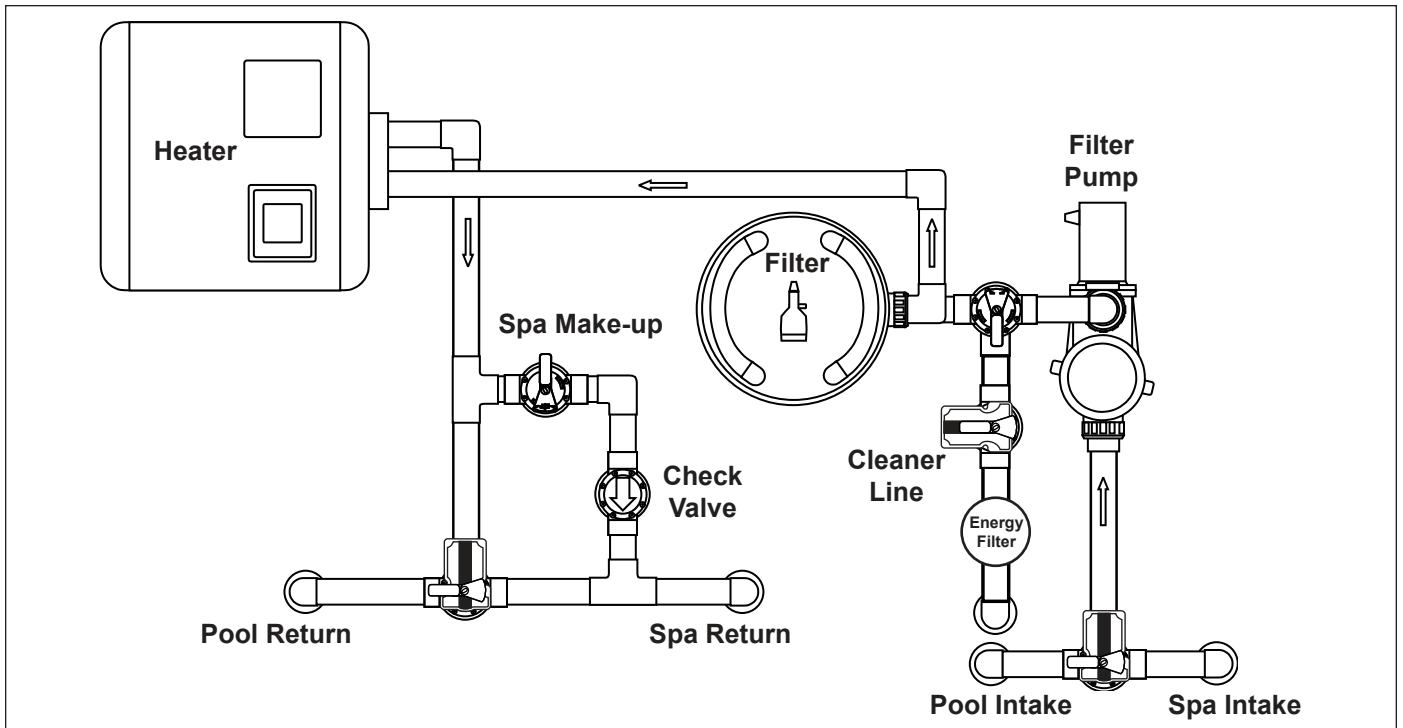

Section 3. Installation

3.1 Power Center Mounting

1. The power center should be located at or near the equipment pad. Locate the power center at least five (5) feet or more away from pool/spa and five (5) feet off the ground. All national, state, and local codes are applicable.

NOTE For Canadian installations, the power center must be at least three (3) meters (9.8 feet) away from the pool/spa and 1.5 meters (5 feet) above the ground.

2. Use the mounting brackets and instructions provided with the standard power center and/or sub-panel power center.
3. Sub-panel power centers have special code requirements. Be sure to follow all applicable local and state codes to insure safe installation.

NOTE The power center is not to be considered as suitable for use as service equipment. Therefore, it is required to have the appropriate means of disconnection, circuit isolation, and/or branch circuit protection installed *upstream* of the power center.

3.2 High Voltage Wiring

3.2.1 System Power

WARNING

Potentially high voltages in the AquaLink® RS Power Center can create dangerous electrical hazards, possibly causing death, serious injury or property damage. Turn off power at the main circuit of the AquaLink® RS Power Center to disconnect the Power Center from the system. To properly and safely wire the system, be sure to carefully follow the applicable requirements of the National Electrical Code (NEC), NFPA 70 or the Canadian Electrical Code (CEC), CSA C22.1. All applicable local installation codes must also be adhered to.

Depending on the amount of equipment being controlled, run ½" or ¾" conduit from the power supply panel to the bottom of the power center. If you are using the sub-panel power center, wire power to the appropriate breakers. Pull in

appropriate wire for equipment. Each piece of equipment requires its own high voltage relay. Connect 120 volts to the power center terminals. Connect equipment ground(s). See Figures 1 and 2.

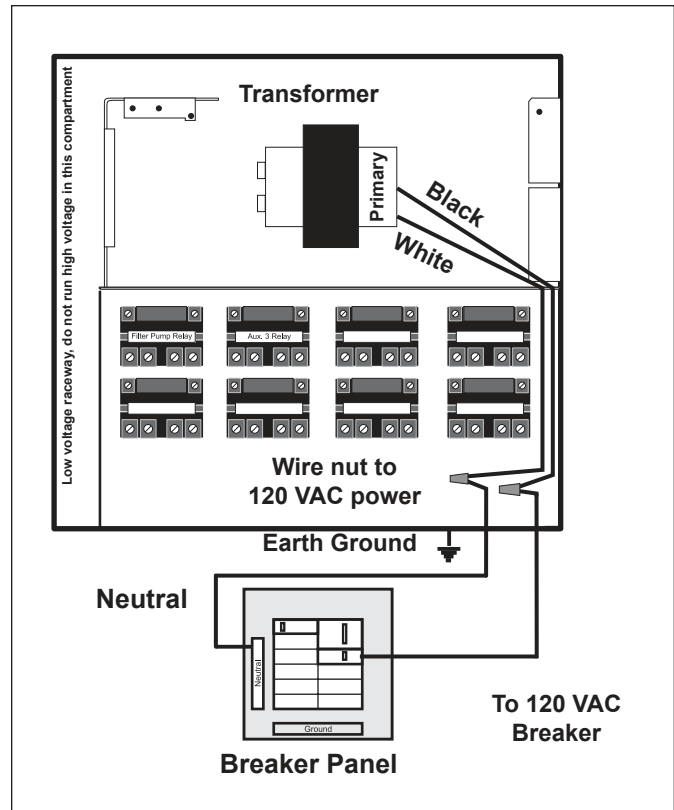

Figure 1. Standard Power Center

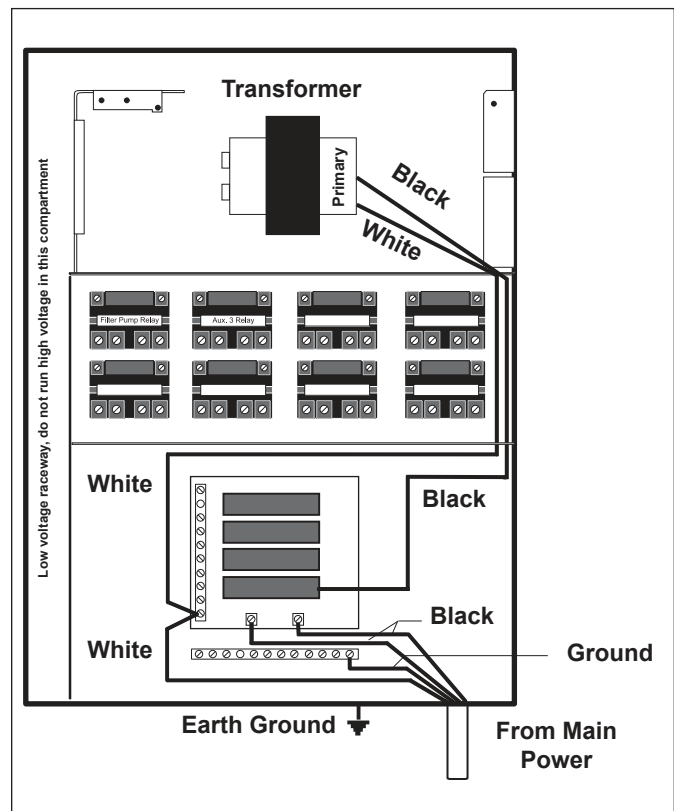

Figure 2. Sub-Panel Power Center

3.2.2 3HP (Standard) Relays

For each piece of **240 volt** equipment to be controlled, **connect line power to the two (2) line terminals** and **connect equipment power to the two (2) load terminals** on the same relay.

For each piece of **120 volt** equipment, **connect power to a line terminal** and **connect equipment to a load terminal** on the same relay.

NOTE The following are the contact ratings for 3HP (Standard) Relay. DO NOT exceed any ratings.
 3 HP @ 240 VAC; 1½ HP @ 120 VAC; 25 Amps; 1500 Watts.

3.2.3 Bonding the Power Center

Install a bonding lug to the power center enclosure. Connect the bond lug, using a #8 solid copper core wire, to an approved earth ground (an approved ground stake, grid, or conducting metal water pipe buried to a sufficient depth).

See Figure 3.

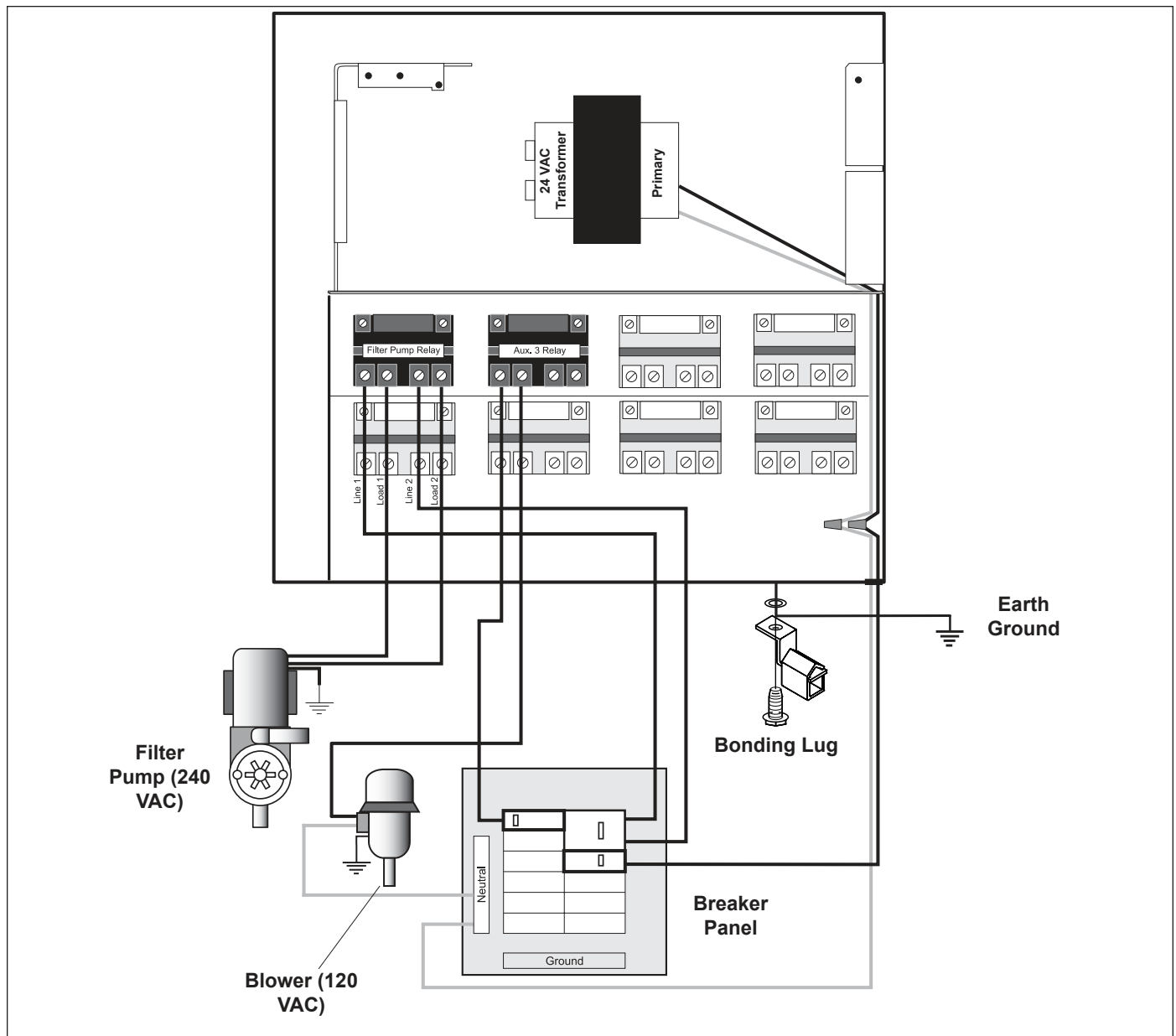

Figure 3. Standard Power Center - Bonding

3.2.4 High Voltage Underwater Lighting GFCI Wiring

CAUTION

A Ground Fault Circuit Interrupter (GFCI) *must* be provided in high voltage pool/spa lights. The conductors on the load side of the GFCI device shall not occupy conduit, boxes, or enclosures containing other conductors unless the other conductors are also on the load side of a GFCI, or unless the other conductors are segregated, separated by barrier(s) or routed and secured to provide permanent spacing from the conductors on the load side of the GFCI. Refer to local codes for complete details.

1. For a standard power center, install a GFCI receptacle next to the breaker panel. For a sub-panel power center install a GFCI receptacle in the power center (use the knockout provided on the right side of the sub-panel power center). See Figure 4.
2. Connect neutral and hot wire (from circuit breaker) to the LINE side of the GFCI.
3. Connect neutral (white wire) and the hot (black wire) from the light to the LOAD side of the GFCI.
4. Connect ground from the light to the grounding bar inside the power center.

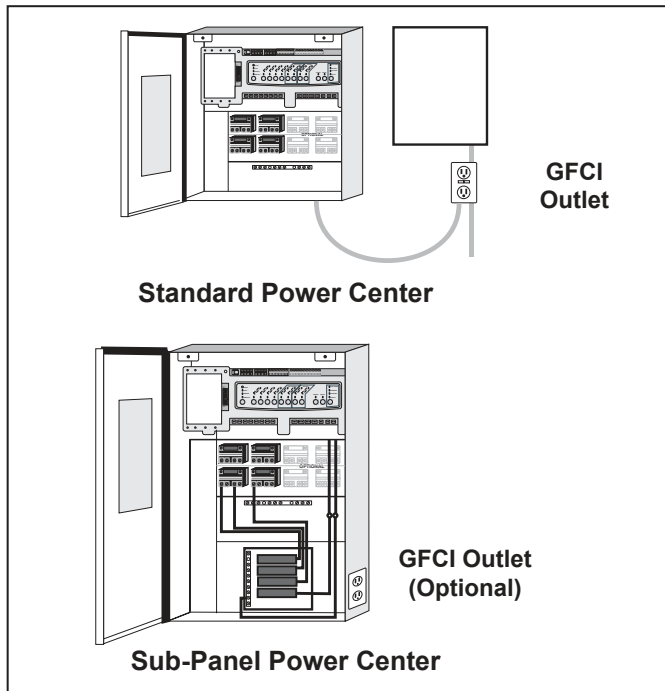

Figure 4. GFCI Installation for High Voltage Underwater Lighting

3.2.5 Jandy Pool and Spa Lights Wiring

The **Jandy Pool and Spa Lights** can be wired into the Jandy AquaLink® RS control system to ensure simplified operation of the lights, as well as a means to synchronize the color change function. Connect the lights to one of the auxiliary relays in the power center.

NOTE It is recommended to connect one (1) light per relay so each light can be controlled separately. However, up to four lights can be connected on a single relay. If there are more than four (4) lights installed on one AquaLink® RS system, ensure there is more than one (1) auxiliary relay available in the Power Center.

Refer to Figures 5 and 6 to connect the Jandy pool and spa lights to the power center.

NOTE The Jandy pool and spa lights are available in 120-volt and 12-volt versions. If installing a 12-volt light, a 120-volt/12-volt step-down (AC) transformer must be used. For more information about 12-volt installations, refer to the *Jandy Digital, Color Changing, Underwater Pool and Spa Lights Installation and Operation Manual*.

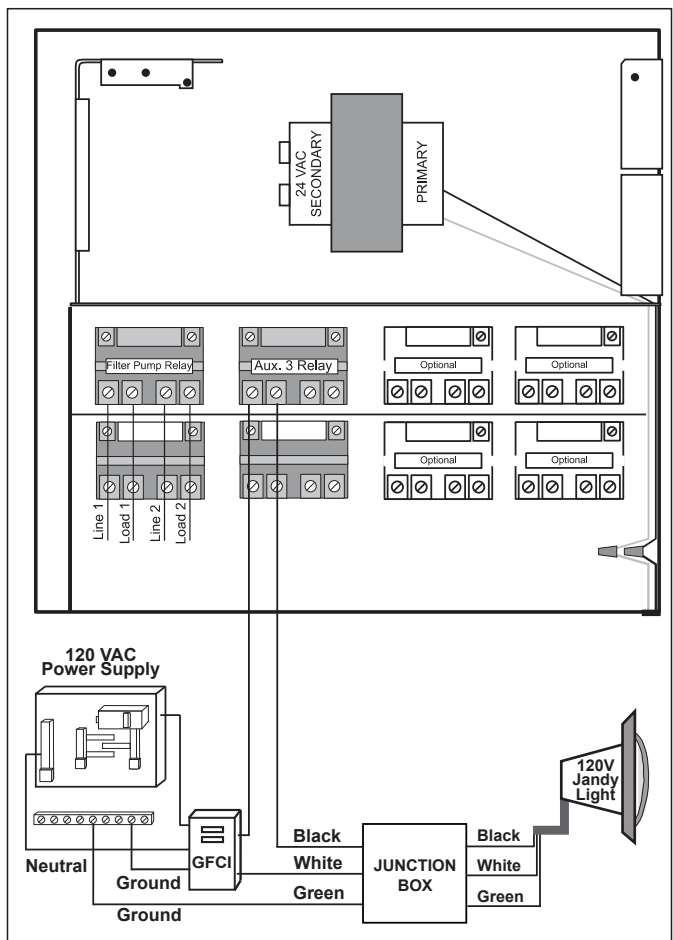

Figure 5. 120-Volt Jandy Pool and Spa Light Wiring Diagram

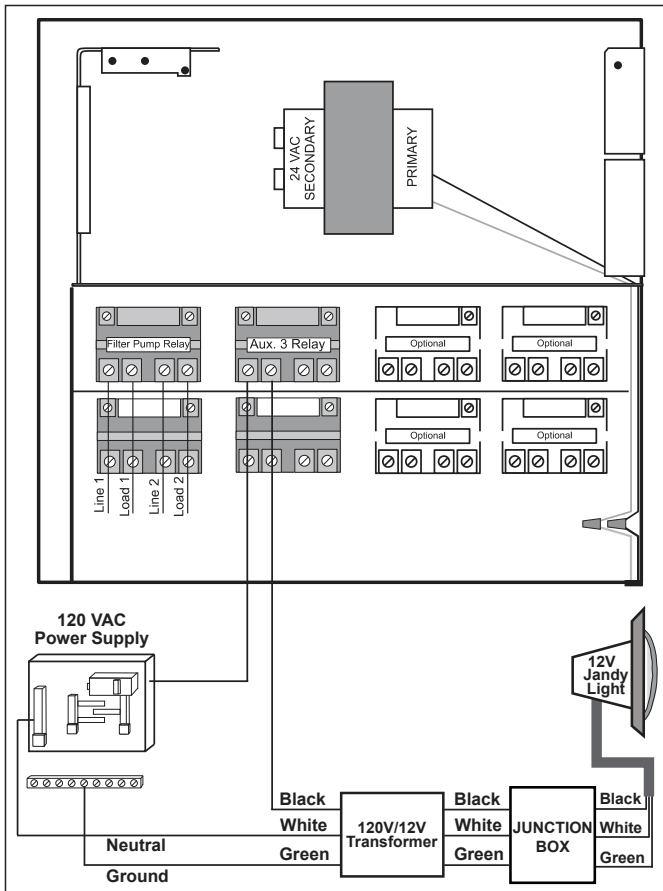

Figure 6. 12-Volt Jandy Pool and Spa Light Wiring Diagram

3.2.6 Variable Speed Pump Wiring (High Voltage)

With the AquaLink® RS it is possible to control four different types of variable speed pumps. This section describes how to supply AC power to the pumps. For instructions on how to connect the low voltage communications wiring (RS485) see Section 3.3.3. It is recommended to connect the variable speed pump to a relay.

3.2.7 Pentair®¹ Variable Speed/Flow Pumps

⚠ WARNING

Potentially high voltages in the AquaLink® RS power center can create dangerous electrical hazards, possibly causing death, serious injury or property damage. Turn off power at the main circuit of the AquaLink® RS power center to disconnect the power center from the system. To properly and safely wire the system, be sure to carefully follow the applicable requirements of the National Electrical Code (NEC), NFPA 70 or the Canadian Electrical Code (CEC), CSA C22.1. All applicable local installation codes must also be adhered to.

To connect a Pentair variable speed/flow pump to the AC power.

1. Make sure all electrical breakers and switches are turned off before wiring the motor.
2. Make sure that the wiring voltage is 230 VAC.
3. Use #12 AWG for wire runs up to 100 feet and #10 AWG for lengths longer than 100 feet. When in doubt use a heavier gauge (larger diameter) wire. Heavier gauge will allow the motor to run cooler and more efficient.

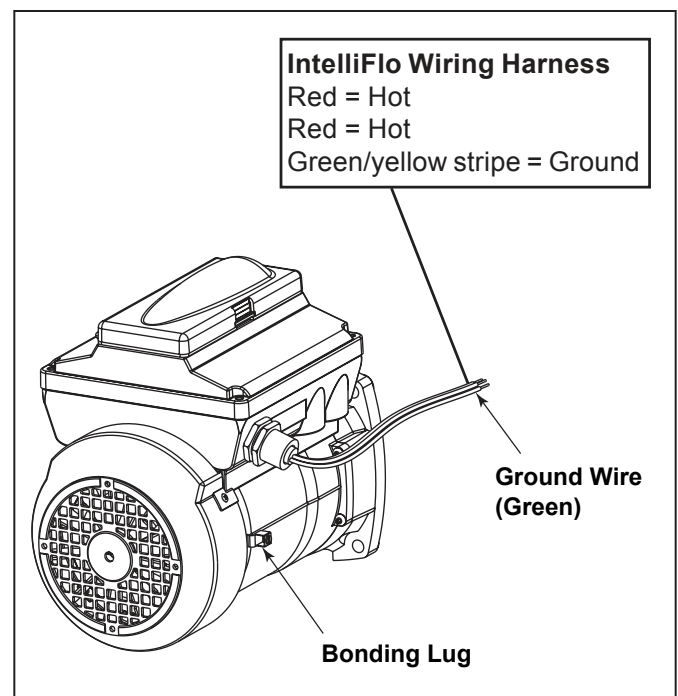

Figure 7. Pentair External Bonding

¹ Pentair is a registered trademark of Pentair Pool Products, Inc.

4. Make sure all electrical connections are clean and tight.
 5. Cut the wires to the appropriate length so they do not overlap or touch when connected.
 6. Permanently ground the motor using the green ground wire, as shown in Figure 7. Use the correct wire size and type specified by National Electrical Code (NEC) and the Canadian Electrical Code (CEC). Make sure the ground wire is connected to an electrical service ground.
 7. Bond the motor to the pool structure in accordance with the National Electrical Code (NEC) and the Canadian Electrical Code (CEC). Use a solid No. 8 AWG or larger copper conductor. Run a wire from the external bonding lug to the pool bonding structure, as shown in Figure 7.
 8. Connect the two red hot wires of the pump to the two load side connections on the filter pump relay as shown in Figure 7.
3. Use #12 AWG for wire runs up to 100 feet and #10 AWG for lengths longer than 100 feet. When in doubt use a heavier gauge (larger diameter) wire. Heavier gauge will allow the motor to run cooler and more efficient.
 4. Make sure all electrical connections are clean and tight.
 5. Cut the wires to the appropriate length so they do not overlap or touch when connected.
 6. Permanently ground the motor using the green ground wire, as shown in Figure 8. Use the correct wire size and type specified by National Electrical Code (NEC) and the Canadian Electrical Code (CEC). Make sure the ground wire is connected to an electrical service ground.
 7. Bond the motor to the pool structure in accordance with the National Electrical Code (NEC) and the Canadian Electrical Code (CEC). Use a solid No. 8 AWG or larger copper conductor. Run a wire from the external bonding lug to the pool bonding structure, as shown in Figure 8.
 8. Connect the red and black wires of the pump to the two load side connections on the filter pump relay as shown in Figure 8.

3.2.8 Jandy ePump™ DC Variable Speed Pump

⚠ WARNING

Potentially high voltages in the AquaLink® RS power center can create dangerous electrical hazards, possibly causing death, serious injury or property damage. Turn off power at the main circuit of the AquaLink® RS power center to disconnect the power center from the system. To properly and safely wire the system, be sure to carefully follow the applicable requirements of the National Electrical Code (NEC), NFPA 70 or the Canadian Electrical Code (CEC), CSA C22.1. All applicable local installation codes must also be adhered to.

To connect a Jandy variable speed pump to the AC power.

1. Make sure all electrical breakers and switches are turned off before wiring the motor.
2. Make sure that the wiring voltage is 230 VAC.

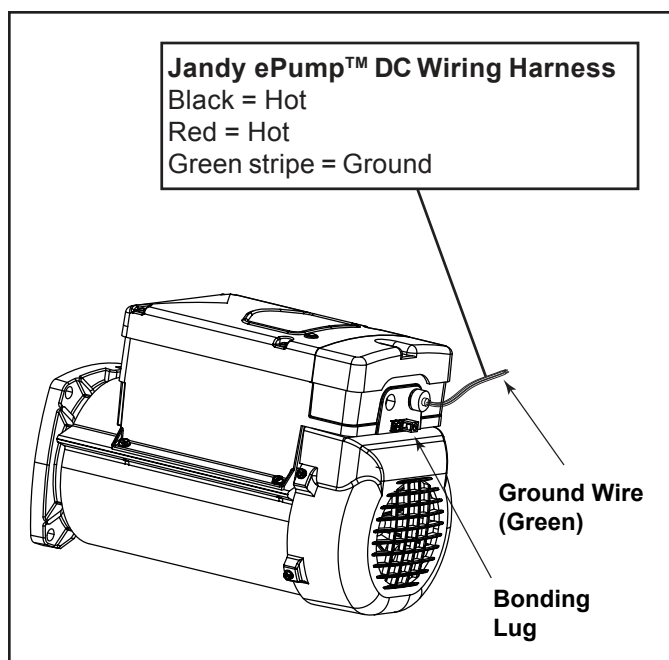

Figure 8. Jandy External Bonding

3.2.9 Jandy ePump™ AC Variable Speed Pump

⚠ WARNING

Potentially high voltages in the AquaLink® RS power center can create dangerous electrical hazards, possibly causing death, serious injury or property damage. Turn off power at the main circuit of the AquaLink® RS power center to disconnect the power center from the system. To properly and safely wire the system, be sure to carefully follow the applicable requirements of the National Electrical Code (NEC), NFPA 70 or the Canadian Electrical Code (CEC), CSA C22.1. All applicable local installation codes must also be adhered to.

This section describes how to connect a Jandy ePump™ AC variable speed pump to the power. As shown in Figure 9, the 230VAC single phase power is supplied to the motor drive. The motor drive supplies the motor with 230VAC three phase power. Low voltage RS485 communications cable from the power center is supplied to the motor drive as well.

1. Make sure all electrical breakers and switches are turned off before wiring the motor.
2. Make sure that the wiring is 230VAC single phase.
3. Use #12 AWG for wire runs up to 100 feet and #10 AWG for lengths longer than 100 feet. When in doubt use a heavier gauge (large diameter) wire. Heavier gauge will allow the motor to run cooler and more efficient.
4. Make sure all electrical connections are clean and tight.
5. Cut the wires to the appropriate length so they do not overlap or touch when connected.
6. Permanently ground the motor using green ground wire, as shown in Figure 9. Use the correct wire size and type specified by the National Electrical Code (NEC) and the Canadian Electrical Code (CEC).

7. Bond the motor to the pool structure in accordance with the National Electrical Code (NEC) and the Canadian Electrical Code (CEC). Use a solid No. 8 AWG or larger copper conductor. Run a wire from the external bonding lug to the pool bonding structure, as shown in Figure 9.

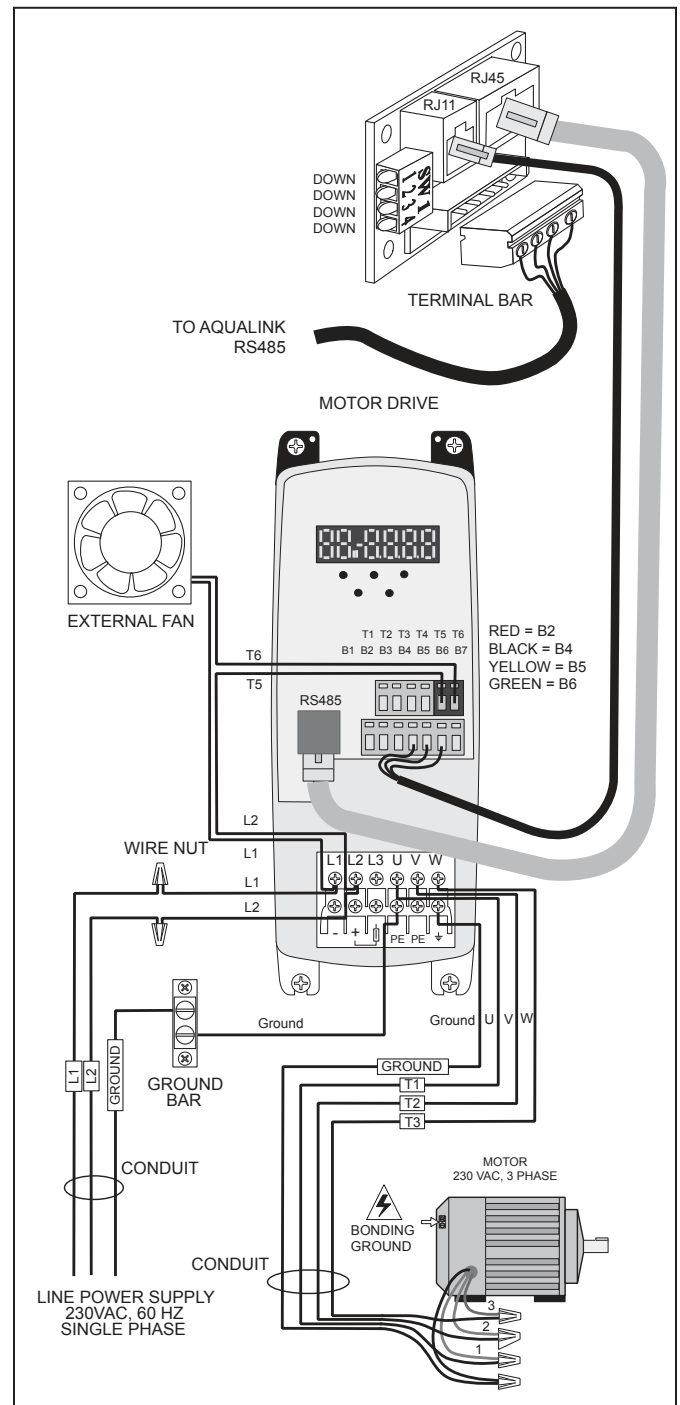

Figure 9. Wiring of the Jandy ePump™ AC Variable Speed Pump to the Motor Drive

8. Connect the red and black wires (L1 and L2) of the motor drive to the two load side connections on the filter pump relay as shown in Figure 10. If the pump is not to be used for filtration then you would connect the red and black wires to the load side connections of an AUX relay.
9. Connect the black (U), red (V), blue (w), and green wires from the motor drive to the pump motor.

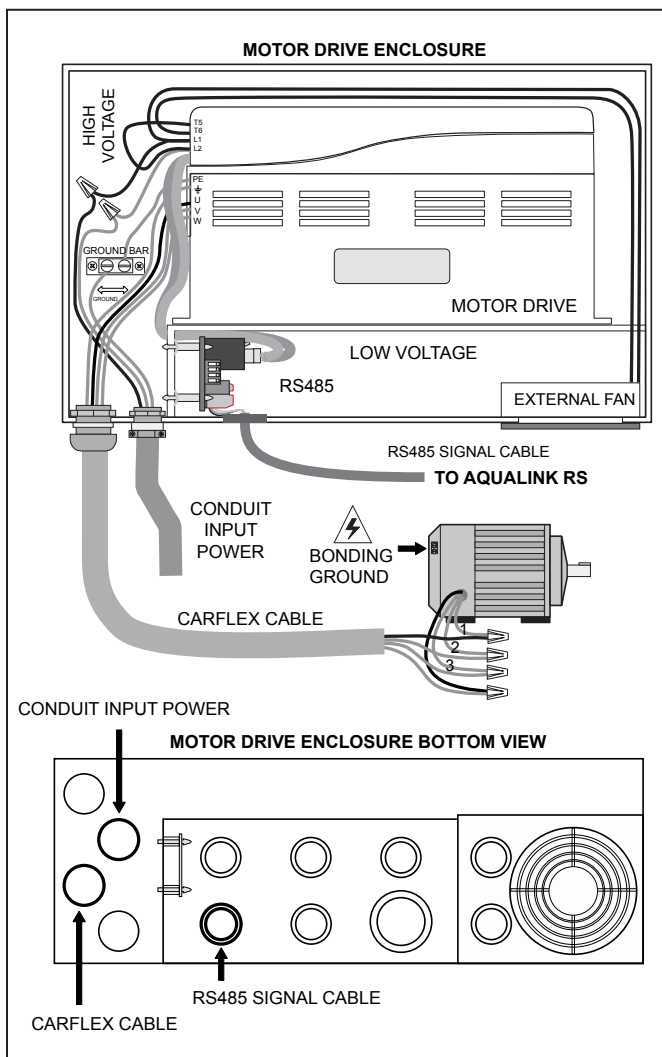

Figure 10. Wiring of the Jandy ePump™ AC Variable Speed Pump to the Enclosure

3.3 Low Voltage Wiring

Minimum wire size should be 22 AWG. If wire run is more than 300 feet, larger wire should be used.

3.3.1 Bezel Connection

Plug the 24 VAC power plug from the transformer into its 3-pin terminal on the back of the power center PCB as shown in Figure 11. Mount the bezel to the power center using the screws provided.

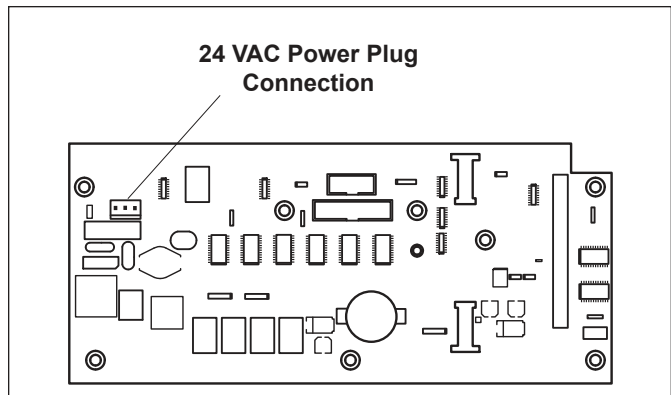

Figure 11. Power Center PCB (back view)

3.3.2 Control Panel Cable to Power Center PCB

Make provision for the four conductor, 22 AWG or larger cable to be run between the indoor control panel and the power center. **Never run high voltage and low voltage in the same conduit.** Pull cable through the knockout with the Heyco®¹ fitting and into the low voltage compartment. Strip back jacket 6". Strip each wire a ¼" and connect to the red, 4-pin connector on the power center PCB. A multiplex kit may be required if there are more than two cables running to a red, 4-pin connector. See Figure 12.

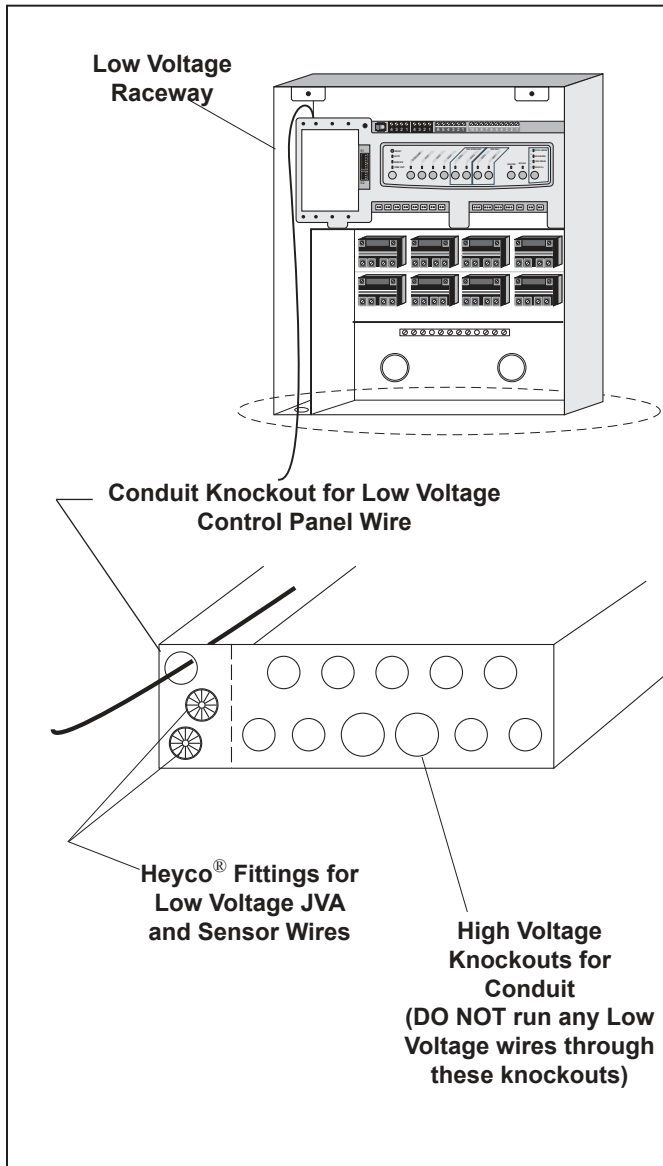

Figure 12. Control panel Cable to Power Center PCB

3.3.3 Variable Speed Pump to Power Center PCB Cable

The low voltage wiring for the variable speed pumps consists of the RS485 communications four conductor, 22 AWG or larger cable. Make provision for the cable to be run between the pump and the power center. **Never run high voltage and low voltage in the same conduit.** Pull cable through the knockout with the Heyco® fitting and into the low voltage compartment. Strip back jacket 6". Strip each wire a ¼" and connect to the red, 4-pin connector on the power center PCB. A multiplex kit may be required if there are more than two cables running to each of the red, 4-pin connectors on the power center PCB. See Figure 13.

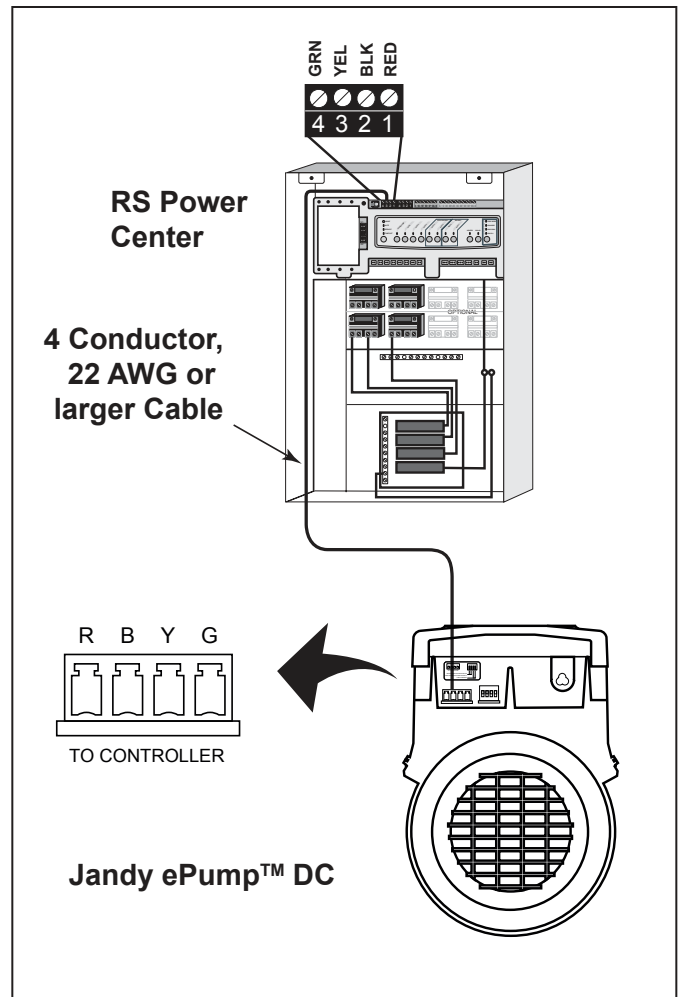

Figure 13. Low Voltage Wiring for Jandy ePump™ DC

¹ Heyco is a registered trademark of Heyco, Inc.

3.3.4 Wiring the Pentair® Pump

The Pentair IntelliFlo® VF LCD control panel is disabled when communicating with the AquaLink® RS system and "DISPLAY NOT ACTIVE" will be displayed. Note that AquaLink® RS will not start communicating with the Pentair® IntelliFlo® VF until it has been configured accordingly. See the AquaLink® RS Owner's Manual (P/N 6593L) for more information.

Connection from the AquaLink® RS power center PCB to the Pentair® variable speed/flow pumps is via the two-wire cable (Pentair® P/N 350122). The cable pin out is shown in Figure 14.

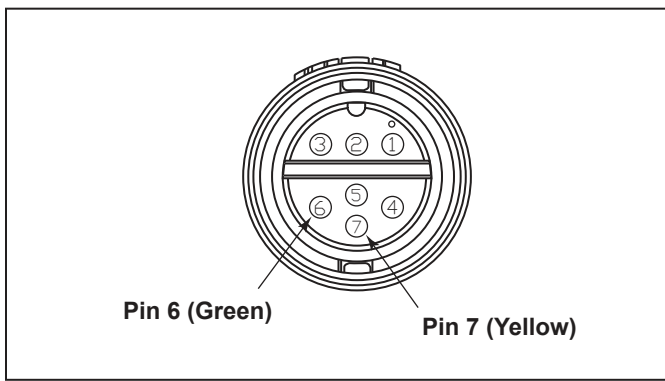

Figure 14. Cable Connector at the Pump Side

Jandy RS485 (RED) Connector	Pentair RS485 Cable Assembly
Pin 1 (no connection)	
Pin 2	Yellow Wire
Pin 3	Green Wire
Pin 4 (no connection)	

3.3.5 Wiring the Jandy ePump™ DC

Connection from the AquaLink® RS power center PCB to the Jandy ePump™ is via an RS485 cable. The cable pin out is shown below.

RS485 Wire Connections for Jandy ePump	
This side connects to J1 or J4 of power center PCB or to the multiplexer PCB.	This side of the cable connects to the Jandy ePump.
Pin 1 (no connection, not used)	Pin 1 (no connection, not used)
Pin 2 (SD+)	Pin 2 (SD+)
Pin 3 (SD-)	Pin 3 (SD-)
Pin 4 (no connection, not used)	Pin 4 (no connection, not used)

3.3.6 Jandy ePump™ DC DIP switch settings

As shown in Figure 15, the 4-position dip switch is located at the rear of the Jandy ePump™. This dip switch serves two functions - it determines what type of control will be used with the pump and it selects the pump address.

The SW 1 (switch 1) and SW 2 are turned ON if the pump is to be controlled by a stand alone controller or OFF if the pump is to be controlled by the AquaLink® RS.

SW 1	SW 2	CONTROL
OFF	OFF	AquaLink® RS
ON	OFF	
OFF	ON	Stand Alone
ON	ON	

The SW 3 and SW 4 are turned ON/OFF to select the pump address.

SW 4	SW 3	PUMP No.
OFF	OFF	1
OFF	ON	2
ON	OFF	3
ON	ON	4

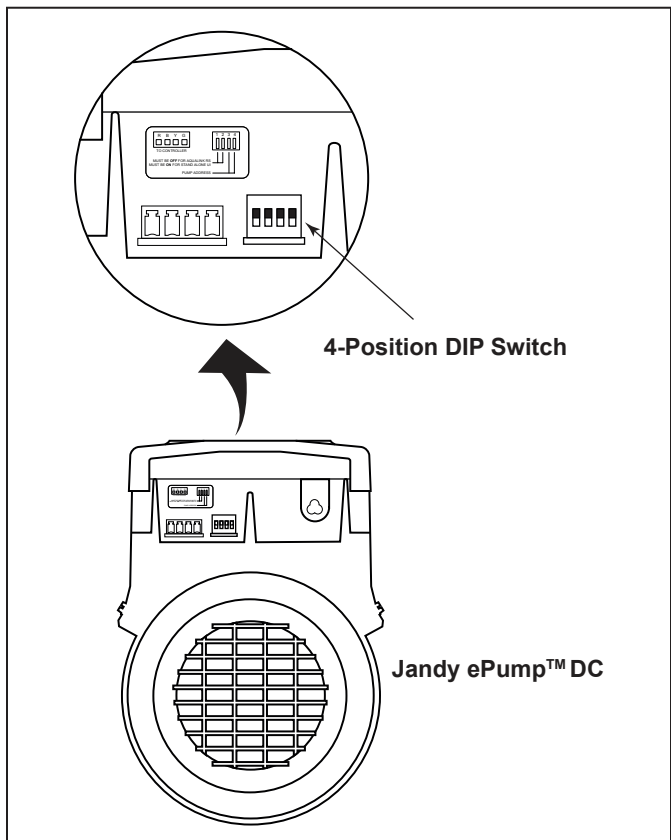

Figure 15. Jandy ePump™ DC Dip Switch

3.3.7 Wiring the Jandy ePump™ AC

RS485 Wire Connections for Jandy ePump AC	
This side connects to J1 or J4 of power center PCB or the multiplexer PCB.	This side of the cable connects to J1 of the Jandy VFD regulator PCB. (Mounted in the motor drive enclosure)
Pin 1 (Not used)	Pin 1 (Not used)
Pin 2 (SD+, Black wire)	Pin 2 (SD+, Black wire)
Pin 3 (SD-, Yellow wire)	Pin 3 (SD-, Yellow wire)
Pin 4 (GND, Green wire)	Pin 4 (GND, Green wire)

3.3.8 Jandy ePump™ AC Switch DIP Settings

As shown in Figure 9, the 4-position dip switch is located on the VFD voltage regulator PCB inside of the motor drive enclosure. This dip switch serves two different functions - it determines what type of control will be used with the pump and it selects the pump address. The SW 1 (switch 1) and SW 2 are turned ON if the pump is to be controlled by stand alone controller or OFF if the pump is to be controlled by the AquaLink® power center.

SW1	SW2	Control
OFF	OFF	AquaLink RS
ON	OFF	
OFF	ON	
ON	ON	Stand Alone Controller

The SW3 and SW4 are turned ON/OFF to select the pump address.

SW3	SW4	Pump Number
OFF	OFF	1
ON	OFF	2
OFF	ON	3
ON	ON	4

NOTE: UP = ON
DOWN = OFF
Refer to Figure 9.

3.4 Heater Connection

The heater connection section applies to all heaters or heat pumps with thermostatic circuitry of 24 VAC or less.

NOTE If you are connecting a heater with thermostatic circuitry of 120 VAC or greater, do not connect to the green, 10-pin terminal bar. Instead connect the heater to a high voltage relay in the power center and plug the spare relay into the electric heater relay socket on the power center PCB.

3.4.1 Jandy Heater Connections

1. Connect two #14 gauge wires, designed for use in hot environments, to the #1 and #2 terminals on the green, 10-pin terminal bar.
2. Connect the other ends of the #14 gauge wires from step 1 to the fireman's switch terminal bar in place of the factory installed wire loop.
3. Do not disconnect high limit or pressure switches.
4. Turn the heater thermostat(s) to maximum setting.
5. Turn the heater switch to the ON position. For dual thermostat heaters turn switch to Spa position.

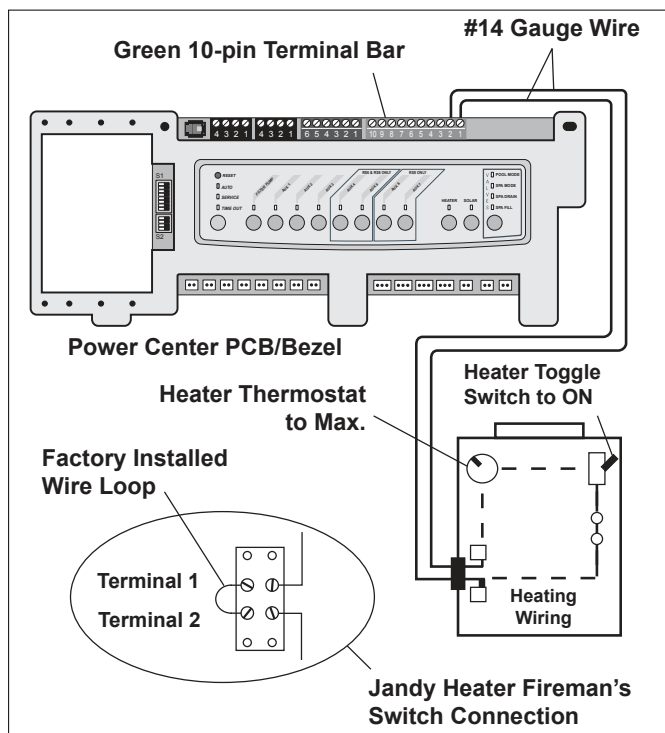

Figure 16. Jandy Heater Connection

3.4.2 Guidelines for Sophisticated Diagnostic Communication to Jandy LX™ Heaters

1. Remove the LX GUI from the heater.
2. Confirm the LX and AquaLink® RS software revisions are compatible (see table).
3. Run a 4-conductor cable from the LX GUI red, 4-pin connector to the RS power Center red, 4-pin connector (see Figure 17).

LX Software Revision	AquaLink® RS Software Revision
C04 to C08	H or HH
C10, C11 or later	I, JJ, K or later

NOTE If connecting more than two (2) items to the RS power center red, 4-pin connector, a multiplex PCB is required.

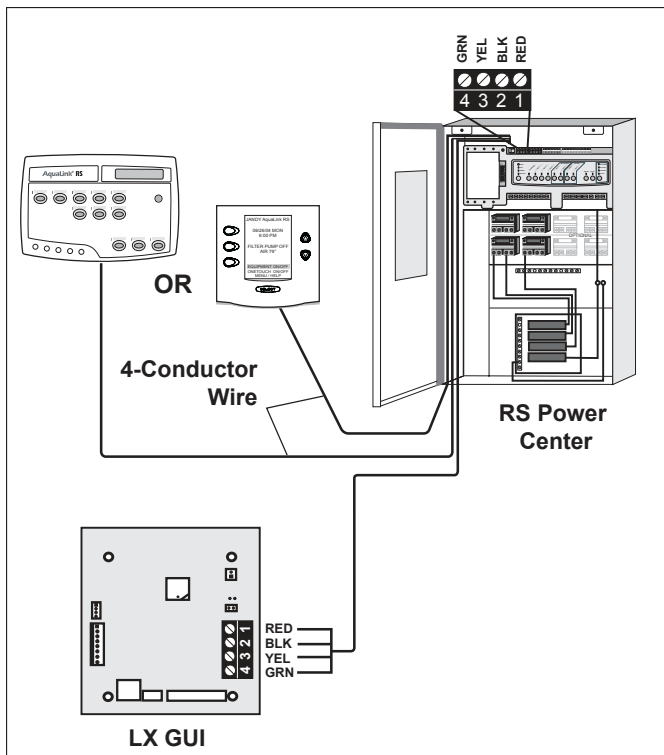

Figure 17. Jandy LX™ Heater Connection to Power Center

3.4.3 Guidelines for Sophisticated Diagnostic Communication to Jandy LXi™ Heaters and Air Energy Heat Pump

1. Confirm the LXi heater or the Air Energy heat pump software and AquaLink® RS software revisions are compatible (see tables below).
2. Run a 4-conductor cable from the LXi heater or the Air Energy heat pump power interface red, 4-pin connector to the RS power center red, 4-pin connector (see Figure 18).

LXi Power Interface Software Revision	AquaLink® RS Software Revision
Any	N or Later

Air Energy Heat Pump Power Interface Software Revision	AquaLink® RS Software Revision
3.0 or Later	N or Later

NOTE If connecting more than two (2) items to the RS power center red, 4-pin connector, a multiplex PCB is required.

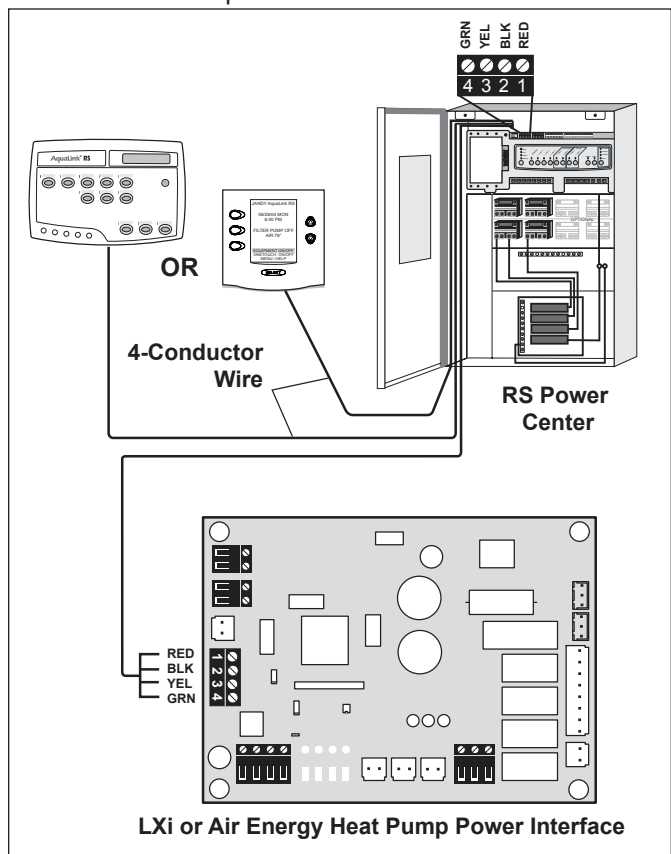

Figure 18. Jandy LXi™ Heater and Air Energy Heat Pump Connection to Power Center

3.4.4 Other Brands Heater and Pump Connections

To set up heater connections on heaters and heat pumps made by other manufactures, please refer to the Installation Manual provided with these heaters and heat pumps.

3.4.5 Guidelines for a Gas Heater and a Jandy AE Series Heat Pump/Chiller Installation

NOTE The following steps provide the procedure for installing a Jandy AE Series Heat Pump and controlling it with the solar pump relay. If your Jandy AE Series Heat Pump is equipped with an RS485 Interface then you do not need to use the solar pump relay to control it. You can control the heat pump via the RS485 interface of the AquaLink® RS.

1. Set DIP switch S2 bit 1 to the ON position. The AquaLink® RS will auto-relabel solar as heat pump.

2. To run the wires from the heat pump control panel, remove the five (5) screws that attach the service/wiring cover panel to the heat pump (see Figure 19).
3. Run the wires from the heat pump control panel through the wiring conduit located on the outer right hand side of the heat pump.
4. Connect the heat pump to a standard relay, then connect the relay to the solar pump output on the AquaLink® RS PCB.
5. The solar button will activate the heat pump/chiller and the pool and/or spa heater buttons will activate the gas heater. In this manner the pool or spa can be heated or chilled by the heat pump, the gas heater or both.

NOTE To program the heat pump control panel, refer to the *Jandy AE Series Heat Pump Manual*.

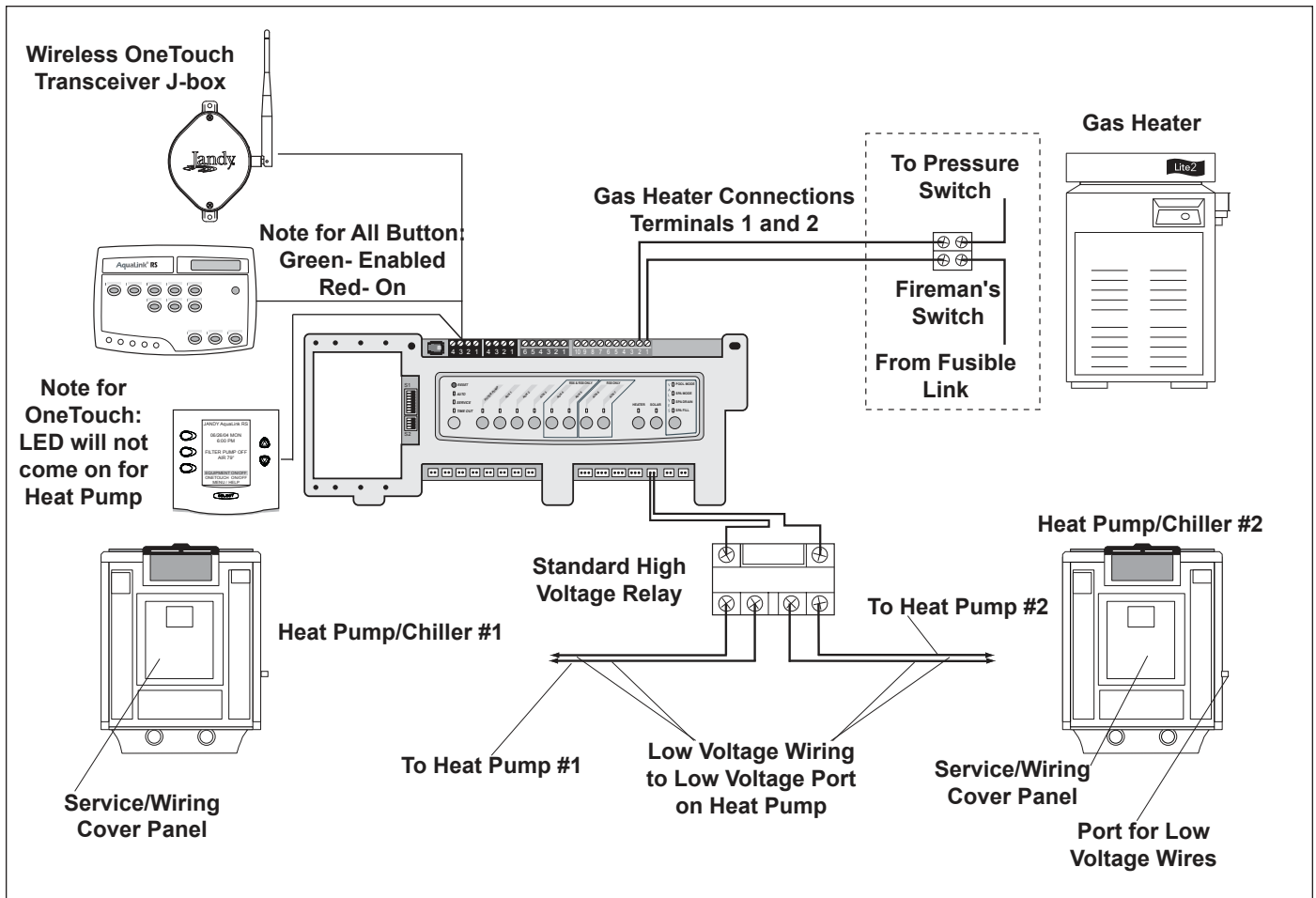

Figure 19. Heater and Heat Pump/Chiller Wiring

3.5 Temperature Sensors

1. Drill 3/8" hole in pipe between filter pump and filter and install the **water temperature sensor** per instructions (make certain the o-ring is in place).
2. Install **air temperature sensor** outside the power center can, not in direct sunlight and away from motors and other heat sources.
3. Install **solar temperature sensor** (optional) adjacent to solar panels.

NOTE If a solar sensor is not installed, the solar button can be labeled and used as an extra auxiliary.

4. Run the wire to the power center, through the low voltage raceway. Cut off excess wire. Strip the wire jacket back 6", then strip each wire 1/4". Connect sensor wires to the green, 10-pin terminal bar (see Figure 20).

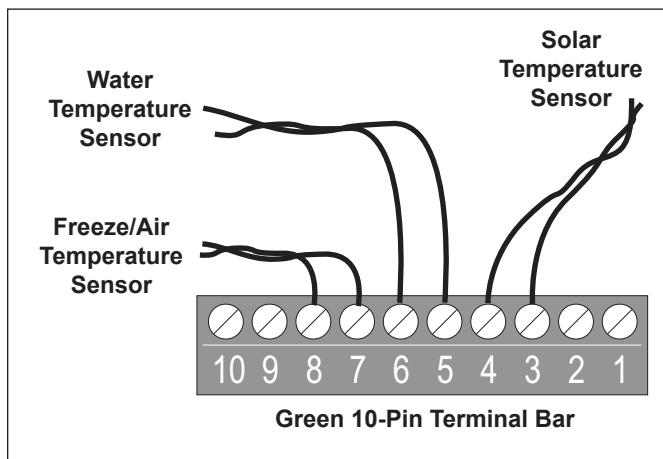

Figure 20. Temperature Sensor Wiring for a Pool/Spa Combination

3.6 Jandy Valve Actuators

NOTE Mount the JVA's according to the *Jandy Valve Actuator Installation and Operation Manual*.

JVA cable is type SJW-A marked water resistant class 3 cable and does not require conduit. Knockouts and Heyco® fittings are provided in the low voltage raceway.

1. Route the JVA wire to the power center.
2. Run the wire through the low voltage raceway and plug the JVA connectors into their proper sockets (see *Section 6. Power Center Wiring Diagram*). Verify that the

JVA on the suction plumbing is connected to the Intake JVA Socket, and the discharge plumbing is connected to the Return JVA Socket.

NOTE Do not coil the JVA wires inside power center. To shorten the wire, remove the JVA cover and disconnect the wire. Shorten, strip, and reconnect.

3. For alternate plumbing configurations the JVA cam settings can be adjusted as needed. See the *Jandy Valve Actuator Installation and Operation Manual, Cam Setting Chart* for proper settings.

3.7 Auxiliary Power Centers

AquaLink® RS All button models support one (1) auxiliary power center.

AquaLink® RS OneTouch™ models support a maximum of three (3) auxiliary power centers.

1. The auxiliary power centers may be wired "in series", starting from the primary power center (solid line) or wired "in parallel" from the primary power center (dashed line). See Figure 21.

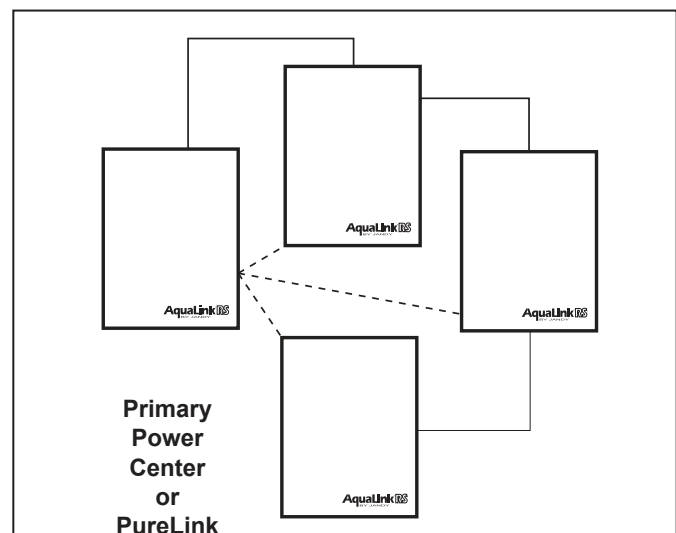

Figure 21. Wiring Multiple Power Centers

- Run four conductor, 22 AWG or larger cable between the red, 4-pin terminal bars in each power center.

NOTE

- All temperature sensors, heater connections and the main filter pump must be wired to the primary power center.
- Never put more than two (2) wires into each of the pins of the red, 4-pin terminal bar (use a Jandy multiplex board).
- If more than one auxiliary power center is installed, set the jumpers as shown in Figure 22.

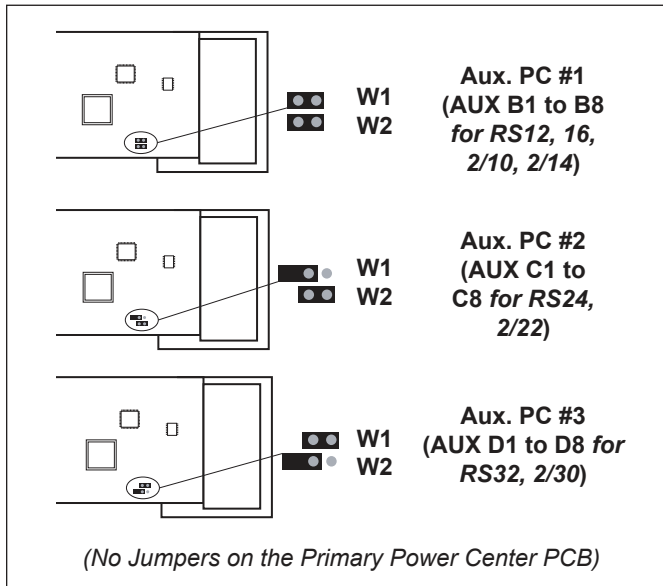

Figure 22. Setting Jumpers for Multiple Auxiliary Power Centers

NOTE In the 2nd, 3rd, or 4th power centers, light dimming relay must be connected to auxiliary B5-B8, C5-C8, or D5-D8.

3.8 All Button Control Panel Installation

3.8.1 Single Indoor Control Panel

- With the aid of the homeowner, find the best location for the control panel.
- Open the indoor control panel assembly by pressing in on the tab located on the lower end of the back of the control panel (see Figure 23). Place the back of the control panel against the wall. Level the back of the control panel and mark the three (3) mounting screw holes and the cable access hole.

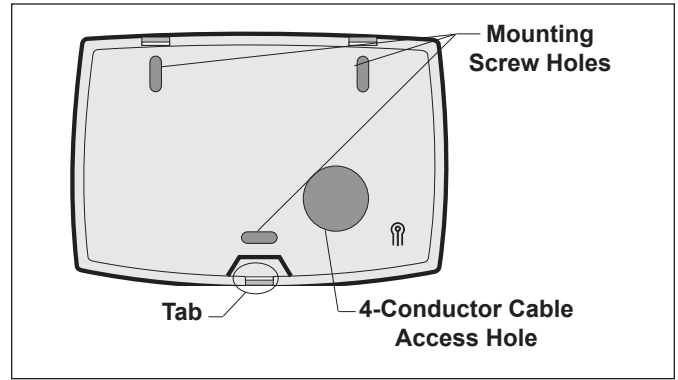

Figure 23. All Button Control Panel - Back View

- Drill 1/4" holes at the three (3) mounting screw marks and insert the plastic anchors. Drill a 1 1/4" (min.) to 2" (max.) hole for cable access.
- Mount the back of the control panel housing to the wall and secure in place.
- Pull the 4-conductor, 22 AWG or larger cable through the access hole and tie a loose knot to prevent the cable from slipping back through the access hole. Strip cable jacket 6", and each individual wire 1/4".
- Remove the red, 4-pin terminal bar from the control panel PCB. Connect the 4 conductor cable to the red, 4-pin terminal bar (see Figure 24). Reconnect the red, 4-pin terminal bar back to the Control Panel PCB.

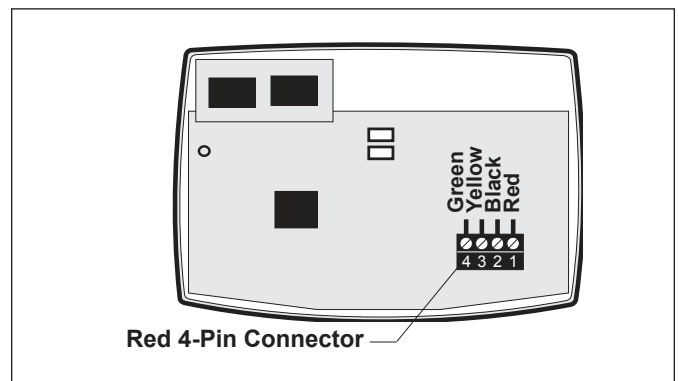

Figure 24. All Button Control Panel PCB

- Hang the control panel front over the two tabs at the top of the control panel back. Swing the bottom of the control panel front down and snap into place.

3.8.2 Multiple AquaLink® RS All Button Control Panel Installation

The AquaLink® RS allows each system to support a maximum of 4 indoor control panels (see Figure 25). The control panels may be wired "in series" starting from the first control panel (solid lines), or wired "in parallel" from the AquaLink® RS power center (dotted lines), or any combination of the two. In other words, any number of Indoor control panels and/or power centers can be connected by means of the red, 4-pin terminal bar in any combination of "series" or "parallel" wiring.

NOTE Minimum wire size should be 22 AWG. If more than one control panel is installed, or the length of run is more than 300 feet, larger wire should be used.

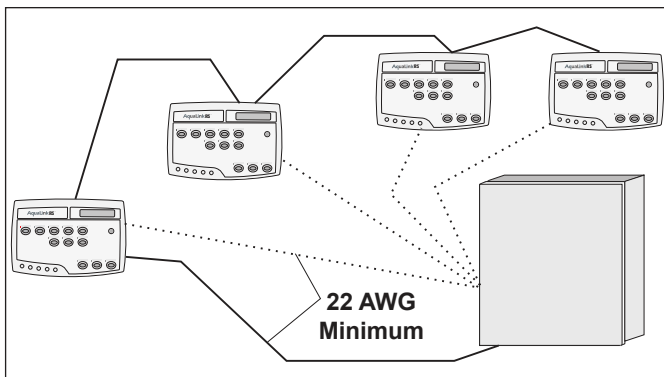

Figure 25. Installing Multiple All Button Control Panels

3.8.3 AquaLink® RS Control Panel Jumper Settings:

Move these jumpers only when installing more than one control panel on a system (see Figure 26). The jumpers are used to give each control panel a unique system address. When replacing an existing control panel, change the jumper settings to match those on the one being replaced.

NOTE If an AquaLink® RS personal computer Interface is installed, the AquaLink® RS system will recognize the interface as the fourth all button control panel.

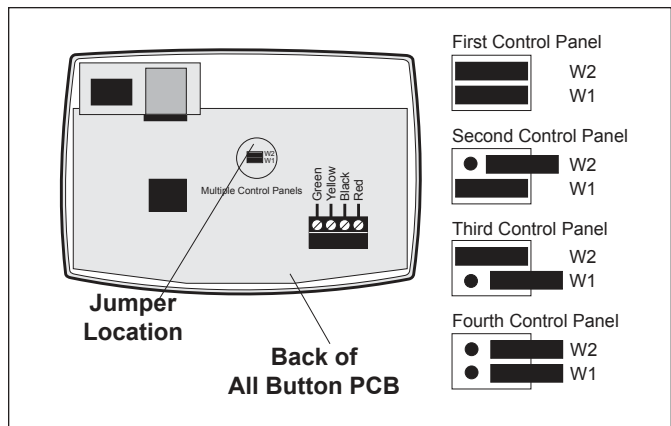

Figure 26. Jumper Settings for Multiple All Button Control Panels

3.9 OneTouch™ Control Panel Installation

3.9.1 Surface Mount OneTouch™ Installation

1. With the aid of the homeowner, find the best location for the control panel.
2. Place surface mount box in the location chosen for the control panel. Mark the holes for drilling. Drill 3/16" holes for the sheet rock anchors and a 1/4" hole for the 4-conductor cable.
3. Run the 4-conductor cable from the power center to the location of the control panel (see Figure 27).

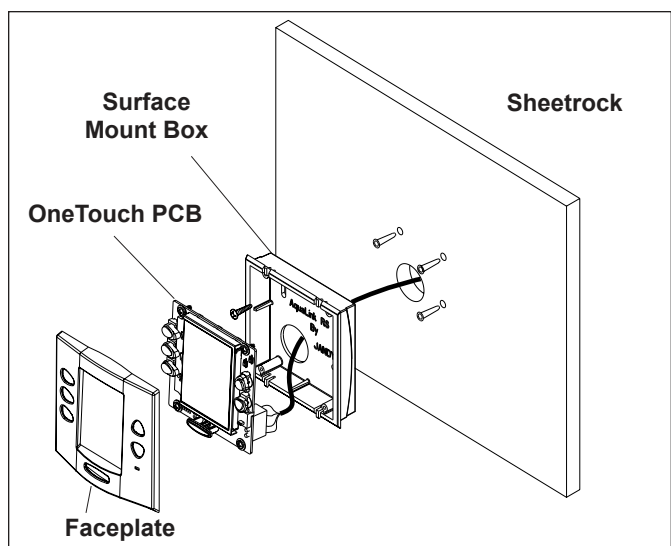

Figure 27. OneTouch™ Surface Mount Installation

4. Pull the 4-conductor cable through the hole in the wall and the hole in the surface mount box. Mount the box to the wall using the screws provided.
5. Wire the 4-conductor cable to the red, 4-pin terminal bar (see Figure 28). Push the 4-pin terminal bar onto the back of the OneTouch PCB. Place the PCB with LCD and buttons back into the box. Insert the screws and hand tighten. **Do not overtighten.** Snap the faceplate into place.

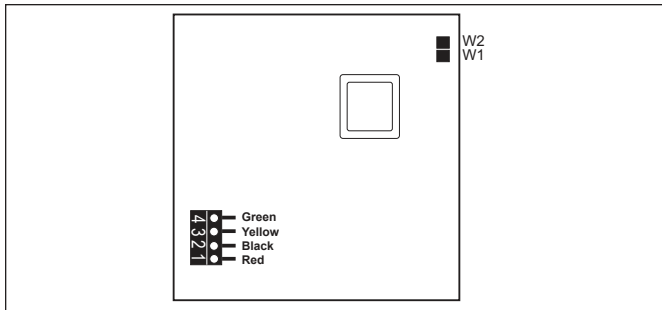

Figure 28. OneTouch PCB - Back View

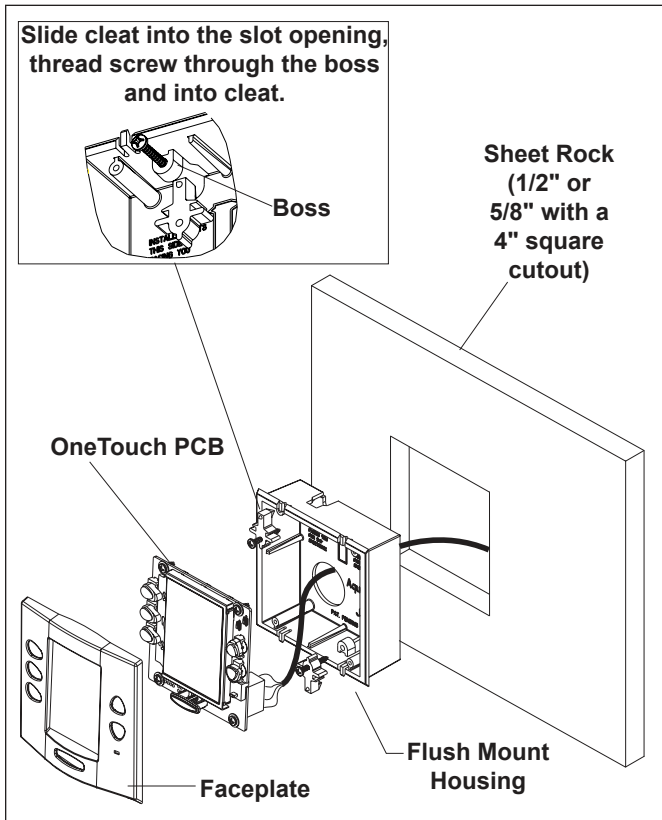

Figure 29. OneTouch™ Flush Mount Installation

3.9.2 Flush Mount OneTouch™ Installation

1. With the aid of the homeowner, find the best location for the control panel.
2. Place the flush mount box in the location chosen for the control panel. Level the box and trace around the outside of the box with a pencil. Cut the hole being careful not to oversize.
3. Route the 4-conductor cable from the power center to the indoor control panel.
4. Pull the 4-conductor cable through the hole in the wall and the hole in the flush mount box. Push the flush mount box into the hole in the wall with the correct orientation (see Figure 29).
5. Depending on what size sheet rock (5/8" or 1/2"), determine which side of the cleat is to be facing you (see Figure 30).
6. Insert a screw through the screw boss (see Figure 29). Put a cleat into the top "U" shaped hole. Hand tighten the screw and repeat the process for the bottom cleat.
7. Wire the 4-conductor cable to the red, 4-pin terminal bar. Push the 4-pin terminal bar onto the back of the OneTouch PCB. Place the OneTouch PCB back into the Flush Mount Housing. Insert the screws with rubber washers and hand tighten. **Do not overtighten.** Snap the faceplate into place.

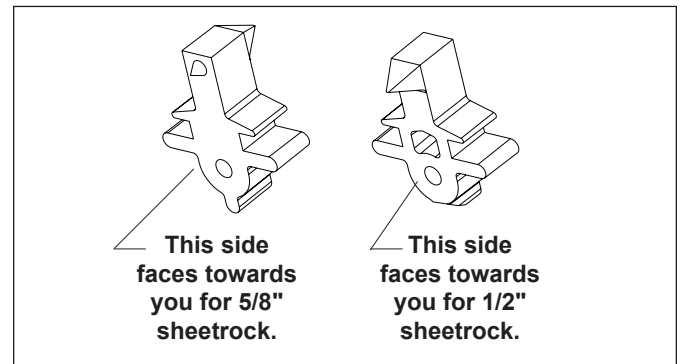

Figure 30. Cleat Orientation

3.9.3 Multiple AquaLink® RS OneTouch Control Panel Installation

The AquaLink® RS allows each system to support a maximum of 4 indoor control panels (see Figure 31). The control panels may be wired "in series" starting from the first control panel (solid lines), or wired "in parallel" from the AquaLink® RS power center (dotted lines), or any combination of the two. In other words, any number of indoor control panels and/or power centers can be connected by means of the red, 4-pin terminal bar in any combination of "series" or "parallel" wiring.

NOTE Minimum wire size should be 22 AWG. If more than one control panel is installed, or the length of run is more than 300 feet, larger wire should be used.

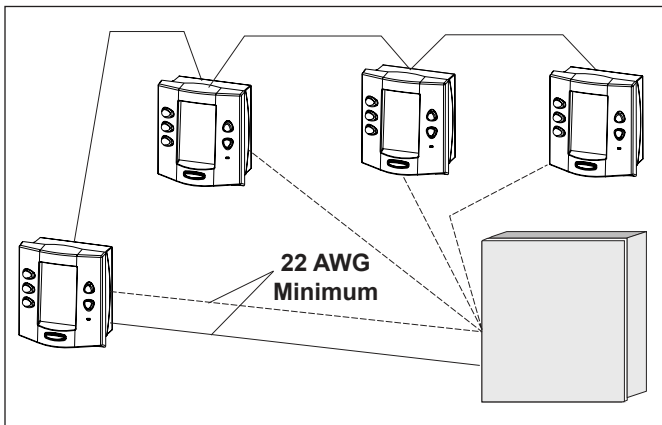

Figure 31. Installing Multiple OneTouch Control Panels

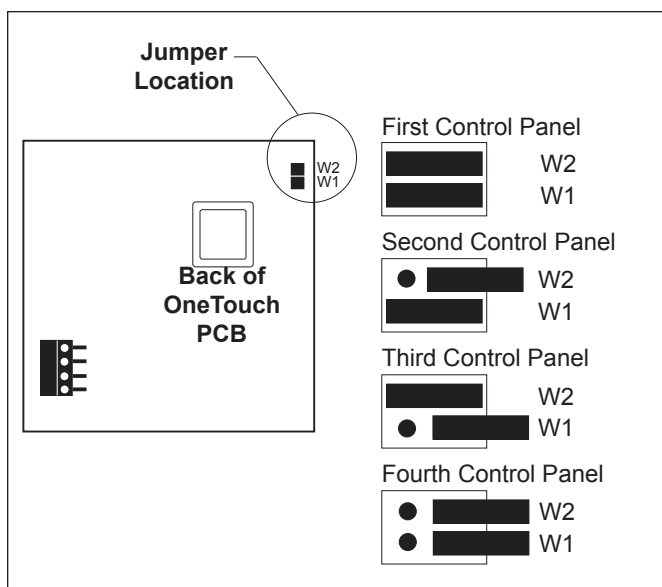

Figure 32. Jumper Settings for Multiple OneTouch™ Control Panels

3.9.4 AquaLink® RS OneTouch Control Panel Jumper Settings

Move these jumpers only when installing more than one control panel on a system (see Figure 32). The jumpers are used to give each control panel a unique system address. When replacing an existing control panel, change the jumper settings to match those on the one being replaced.

3.10 Wireless OneTouch™ Control Panel Installation

Installation Considerations. The transceivers will transmit through walls and around corners. Steel framing, aluminum siding, wrought iron, cyclone fences, leaded glass, microwave ovens, and other 2.4 GHz frequency items may inhibit/prevent communication between the wireless AquaLink® RS control panel and the power center. The transceivers do not require line of sight to communicate. To optimize communication, locate transceivers to minimize interference. The battery wireless AquaLink® RS system requires OneTouch indoor PCB revision "E" or later and firmware revision "B11" or later in order to work properly.

NOTE All new Wireless AquaLink® RS indoor and outdoor transceiver boards (PCB assembly 7983 Rev B) use a C03 (or later) circuit chip and **are not compatible** with the earlier revision of the PCB that use a C02 (or earlier) chip.

3.10.1 Outdoor Transceiver J-box Installation

1. Turn off all power to the power center.
2. Mount the outdoor transceiver J-box at least 6' above the ground and at least 8' from an air blower (see Figure 33).
3. Open the door to the power center and remove the dead panel.
4. Feed the four conductor wire into the power center through the low voltage raceway.
5. Cut off the excess wire. Strip the jacket back 6" and strip the individual wires approximately ¼". Connect the four conductor wire to the red terminal bar on the power center PCB.
6. Install the dead panel to the power center and restore all power.

3.10.2 Indoor Control Panel Installation

1. Connect the transformer to the back of the control panel (see Figure 34).
2. Plug the transformer into a wall socket.
3. **Charge for 24 hours before removing the power supply/charger (the system is operational while charging).**

3.10.3 Changing the Transmission Code

If your AquaLink® RS system is turning items on or off at undesigned times, another AquaLink® RS wireless control panel may be in close proximity using the same or similar code. To prevent unwanted operation, the code for your AquaLink® RS wireless system can be personalized.

Note that is possible to set multiples DIP switches differently on two different systems and yet they will be transmitting on the same channel.

Therefore, to prevent interference with an adjacent wireless system, it is important that the calculated communication channel numbers are not identical between the adjacent systems.

As shown in table on next page, the recommended settings for the system ID DIP switches is limited to ten settings.

Except for DIP switch #8, both the power center transceiver and the control panel transceiver **must be set to the same code**. The indoor control panel transceiver DIP switch #8 must be **OFF** and the power center transceiver DIP switch #8 must be **ON**.

Change the transmission code as follows:

1. At the indoor control panel, remove the screws to expose the transceiver PCB.
2. Locate the small set of DIP switches on the control panel PCB (see Figure 35). Except for DIP switch #8, turn on one or more DIP switches. **Important-** Before installing the control panel cover, press the reset button (SW1). Note which switches you have turned on then reinstall the cover and screws.
3. At the outdoor transceiver J-box, remove the cover to expose the transceiver PCB (see Figure 36). Set the DIP switches (except #8) to the same settings as the control panel transceiver PCB that is in the house. **Important-** Before installing the J-box cover, press the reset button (SW1). Close the cover and test the system.

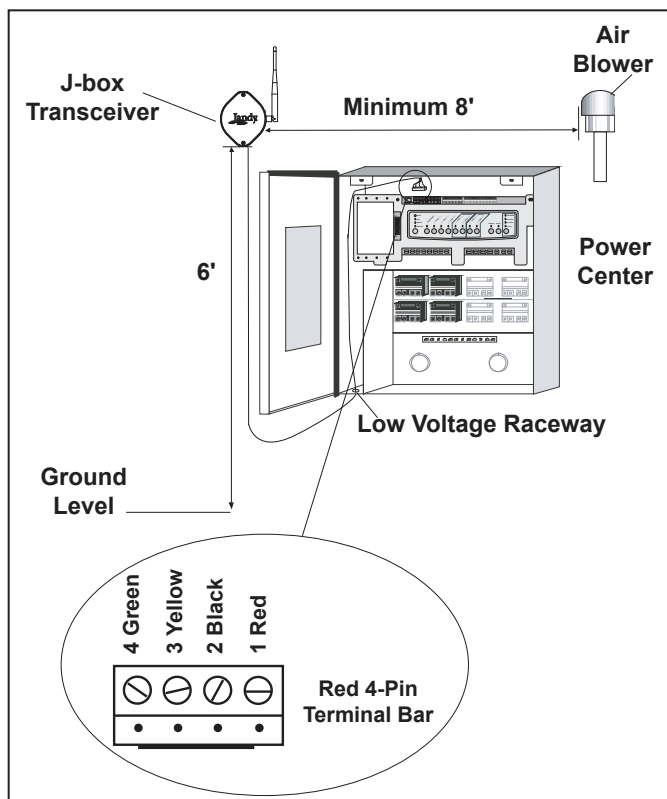

Figure 33. Outdoor Transceiver J-box Installation for Wireless OneTouch™ Control Panel

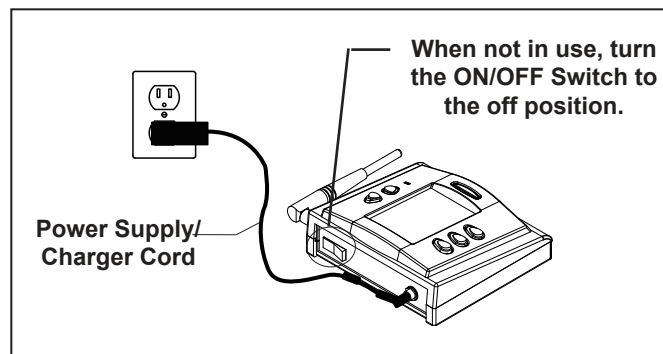

Figure 34. Wireless OneTouch™ Control Panel Installation

Section 4. System Startup

4.1 All Button Programming

4.1.1 Basic Programming

To set a particular piece of equipment to turn on and off at predetermined times, press the MENU button (see Figure 37), scroll to the PROGRAM MENU, press ENTER, and then press the button for the equipment that you want to program. The control panel display will ask you to enter the day. Use the arrow keys to select, and press ENTER. The display will now prompt you for the starting time and ending time. Repeat this process for each piece of equipment that you wish to program. You may enter as many programs as needed for each piece of equipment.

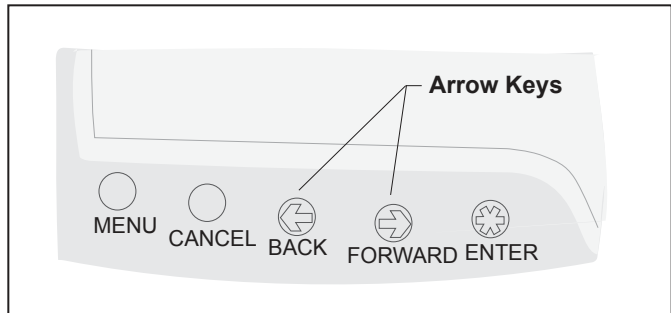

Figure 37. AquaLink® RS All Button Control Panel Buttons

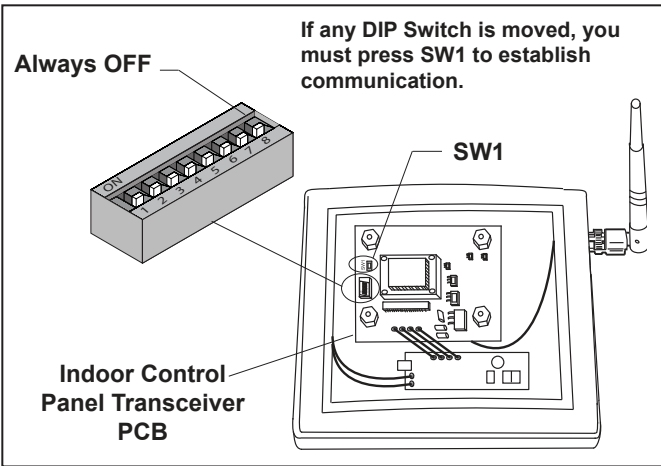

Figure 35. DIP Switch Settings at Wireless Indoor Control Panel

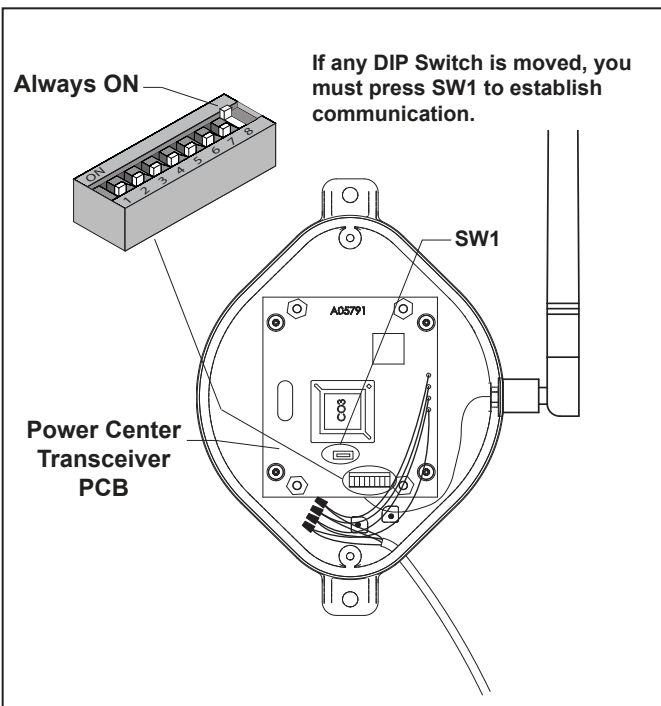

Figure 36. DIP Switch Settings at Power Center J-Box

RECOMMENDED SETTINGS FOR THE SYSTEM ID DIP SWITCHES

Communication Channel	DIP SW 1 (Weight 1)	DIP SW 2 (Weight 2)	DIP SW 3 (Weight 4)	DIP SW 4 (Weight 8)	DIP SW 5 (Weight 16)	DIP SW 6 (Weight 32)	DIP SW 7 (Weight 64)
0	OFF	OFF	OFF	OFF	OFF	OFF	OFF
1	ON	OFF	OFF	OFF	OFF	OFF	OFF
2	OFF	ON	OFF	OFF	OFF	OFF	OFF
3	ON	ON	OFF	OFF	OFF	OFF	OFF
4	OFF	OFF	ON	OFF	OFF	OFF	OFF
5	ON	OFF	ON	OFF	OFF	OFF	OFF
6	OFF	ON	ON	OFF	OFF	OFF	OFF
7	ON	ON	ON	OFF	OFF	OFF	OFF
8	OFF	OFF	OFF	ON	OFF	OFF	OFF
9	ON	OFF	OFF	ON	OFF	OFF	OFF

4.1.2 Set the Time

MENU > SET TIME > YEAR > MONTH > DAY > HOUR > MINUTE

To set the time, press the MENU button. Use the arrow keys to scroll to the SET TIME menu and press ENTER. Now scroll to the correct year, month, and day and press ENTER. Scroll to the correct hour and minute and press ENTER.

NOTE Depending on the version of the AquaLink® RS, the following items can be found either in the Main Menu or in a Sub Menu under SETUP.

4.1.3 Set the Temperature

1. Pool/Spa Combination

MENU > SET TEMP > POOL or SPA > SET TEMP VALUE

Press the MENU button, scroll to the SET TEMP menu, and press ENTER. Use the arrow keys to select POOL or SPA and press ENTER. Once you have selected which heater to set the temperature for, use the arrow keys to select the desired temperature, and press ENTER to complete.

2. Pool/Spa Only

MENU > SET TEMP > SET TEMP1 or SET TEMP2 > SET TEMP VALUE

Press the MENU button, scroll to the SET TEMP menu, and press ENTER. Use the arrow keys to select SET TEMP1 and press ENTER (TEMP1 must be higher than TEMP2). Use the arrow keys to select the desired temperature, and press ENTER to complete. Press the MENU button, scroll to the SET TEMP menu, and press ENTER. Use the arrow keys to select SET TEMP2 and press ENTER (TEMP1 must be higher than TEMP2). Use the arrow keys to select the desired temperature, and press ENTER to complete.

3a. Maintain Temperature

NOTE Maintain Temperature Hours must be set when Maintain Temperature is set, see Step 3b.

MENU > SET TEMP > SET MAINTAIN TEMP

Under the SET TEMP menu, scroll to MAINTAIN and press ENTER. Use an arrow button to select POOL, SPA or OFF. MAINTAIN will run the pump for the chosen body of water to keep the water at the desired temperature. If this function is on, as long as the heater/chiller is enabled for that body of water, the system will automatically turn on the pump every couple of hours for just enough time to test the water temperature.

If the temperature meets the set point, the pump will return to off. If the measured temperature is different than the set temperature, the pump will stay on and the heater/chiller will operate long enough to bring the water to the set temperature.

3b. Maintain Temperature Hours

MENU > SET TEMP > SET MAINTAIN TEMP > SET HOURS

Sets the desired time when this function will activate (default setting is 12AM to 12AM; 24 hours a day). Under SET TEMP scroll to HOURS and press ENTER. Use the arrow keys to change the HOURS the system will maintain the set temperature.

4.1.4 Label Auxiliary Functions

MENU > SYSTEM SETUP > LABEL AUX > CHOOSE LABEL

Press the MENU button, scroll to SYSTEM SETUP and press ENTER. Scroll to the LABEL AUX menu and press ENTER. Press the button (on the control panel) to be labeled (example: AUX1). Scroll to the desired label and press ENTER. Repeat for all functions.

NOTE If DIP switch S1-1, 2 or 3 are on, auxiliaries 1, 2 and 3 are labeled CLEANER, LOW SPEED and SPILLOVER respectively and cannot be relabeled.

4.1.5 Set Freeze Protection

MENU > SYSTEM SETUP > FRZ PROTECT > SELECT EQUIPMENT

The AquaLink® RS freeze protection senses when the air temperature falls below 38° F (3°C) and will automatically turn on the filter pump to circulate the water. To add freeze protection to other equipment press the MENU button. Scroll to SYSTEM SETUP and press ENTER, then scroll to FRZ PROTECT and press ENTER. Press the button for the equipment you want to protect.

4.1.6 Assign JVAs

MENU > SYSTEM SETUP > ASSIGN JVA > SELECT JVA

The assign JVA menu lets you assign Jandy Valve Actuators (JVA) to any auxiliary button. This means that whenever you press that auxiliary button, a valve turns. On pool/spa combination models, there are two JVAs that can be assigned to auxiliary buttons: the Cleaner JVA and the solar JVA (unless the solar function is installed).

NOTE If a solar sensor is installed, the solar JVA will automatically be assigned and will be marked as USED.

On pool only/spa only models, there are four JVAs available. The AquaLink® RS installer must set up these JVAs for this feature to operate correctly. Assigning JVAs lets the owner control certain features like diverting water to a waterfall or bank of spa jets.

To assign JVA values, press the MENU button. Use the arrow keys to scroll to SYSTEM SETUP, press ENTER. Use the arrow keys to scroll to ASSIGN JVA menu and press ENTER. The AquaLink® RS display will read CLEANER JVA. If both JVAs are being used, you will not be able to use this menu.

Use the arrow keys to choose among the JVAs listed. When the JVA you want to assign to an auxiliary is displayed, press ENTER.

The AquaLink® RS display will read SELECT AUX TO ASSIGN JVA TO. Press the button of the auxiliary you want to activate the JVA.

4.2 All Button Reset and Display Messages

4.2.1 Reviewing

MENU > REVIEW > SELECT ITEM TO REVIEW

To review equipment, press the MENU button, then use the FORWARD arrow key to scroll to the REVIEW menu. Press ENTER, use the arrow keys to scroll to the item you wish to review, and press ENTER again.

4.2.2 Canceling Items

CANCEL > SELECT ITEM TO CANCEL

If you make a mistake in programming or you want to change, for example, the ON/OFF times for a specific device, you can cancel programs for that piece of equipment. For example, to **cancel a dimmer**, press the CANCEL button; use the arrow keys to advance to DIMMERS and press ENTER. The AquaLink® RS display will prompt you to select an Aux. Press the button of the auxiliary for which you want to cancel the dimmer.

If you want to cancel a JVA assignment, first press the CANCEL button. Use the arrow keys to scroll to JVA ASSIGNS and press ENTER. The AquaLink® RS display will read CLEANER JVA. Use the arrow keys to toggle between JVAs to cancel. When the JVA assignment that you want to cancel is displayed, press

ENTER. The AquaLink® RS display will read PRESS ENTER TO CANCEL JVA ASSIGNMENT, OR CANCEL TO ABORT. Press ENTER to cancel the JVA assignment, or press CANCEL to abort.

4.2.3 Resetting the System

MENU > SYSTEM SETUP > CLEAR MEMORY

To remove all labeling, programming, assignments, and temperature settings, press the MENU button, use the arrow keys to scroll to SYSTEM SETUP and press ENTER. Scroll to CLEAR MEMORY and press ENTER.

4.3 OneTouch™ Programming

4.3.1. Basic Programming

To set a particular piece of equipment to turn on and off at predetermined times, highlight MENU/HELP and press SELECT (see Figure 38). Highlight PROGRAM and press SELECT. Use the UP or DOWN buttons to highlight the equipment (for example, filter pump) then press SELECT. Follow the on-screen prompts. Use the UP or DOWN buttons to pick each number, starting with ON hours, press SELECT to enter and move on to the next item to change, including picking what day(s) the program will run. If you make a mistake, use the BACK button to return to a number. If the program is already entered, highlight CHANGE PROGRAM and step through to the entry that should be corrected.

A VARIABLE SPEED PUMP can be programmed to run at any one of its eight (8) speeds. Power to the variable speed pump is switched on/off by a relay, so to program the pump you need to set a program time for the relay and for any speeds that you wish to run during the pumps on cycle.

In the example shown below the variable speed pump is used for pool filtration, so it will be powered from the FILTER PUMP relay. Therefore to program the variable speed pump you must first set a program time for the FILTER PUMP relay, then you need to program the desired pump speeds to turn on/off during the FILTER PUMP cycle. If you do not program any speeds to run during the filtration cycle, then by default the variable speed pump will run at the POOL speed setting during its filtration cycle.

Example:

1. The total length of the filtration cycle is to be from 8am to 5pm. So program the FILTER PUMP to turn on at 8am and to turn off at 5pm
2. To run the variable speed pump at the SPEED3 setting from 8am to 1pm, highlight and select VSP SPD1 PGM, then highlight and select SPEED3, program it to turn on at 8am and off at 1pm.
3. To run the variable speed pump at the SPEED4 setting from 1pm to 5pm, highlight and VSP SPD1 PGM, then highlight and select SPEED4, program it to turn on at 1pm and off at 5pm.

	ON	OFF	DESCRIPTION
FILTER PUMP	8AM	5PM	Total duration of filtration cycle
SPEED3	8AM	1PM	Pump runs at the SPEED3 setting
SPEED4	1PM	5PM	Pump runs at the SPEED4 setting

NOTE The following items can be found either in the MENU/HELP or in a Sub Menu under SYSTEM SETUP.

4.3.2 Set the Time Menu

MENU/HELP > SET TIME

To set the time, highlight the MENU/HELP and press SELECT. Highlight SET TIME and press SELECT. Use the UP or DOWN button to set the values. Press SELECT to continue.

4.3.3 Set the Temperature

1. Pool/Spa Combination

MENU/HELP > SET TEMP > POOL or SPA > SET TEMP VALUE

Highlight MENU/HELP and press SELECT. Highlight SET TEMP and press SELECT. Use the UP or DOWN button to highlight either POOL or SPA and press SELECT. Use the UP or DOWN button to increase or decrease the temperature and press SELECT. Use the BACK button to return to the main screen.

2. Pool/Spa Only

MENU/HELP > SET TEMP > TEMP1 > SET TEMP1 VALUE > TEMP2 > SET TEMP2 VALUE

Highlight MENU/HELP and press SELECT. Highlight SET TEMP and press SELECT (TEMP1 must be higher than TEMP2). Press SELECT on TEMP1. Use the UP or DOWN button to increase or decrease the temperature and press SELECT.

Highlight TEMP2 and press SELECT (TEMP1 must be higher than TEMP2). Use the UP or DOWN button to increase or decrease the temperature and press SELECT. Use the BACK button to return to the main screen.

3. Maintain Temperature

MENU/HELP > SET TEMP > MAINTAIN

In the SET TEMP menu, highlighting MAINTAIN and pressing SELECT will turn on (or off) the MAINTAIN function. MAINTAIN will run the pump for the chosen body of water to keep the water at the desired temperature. If this function is on, as long as the heater/chiller is enabled for that body of water, the system will automatically turn on the pump every couple of hours for just enough time to test the water temperature. If the temperature meets the set point, the pump will return to off. If the measured temperature is different than the set temperature, the pump will stay on and the heater/chiller will operate long enough to bring the water to the set temperature.

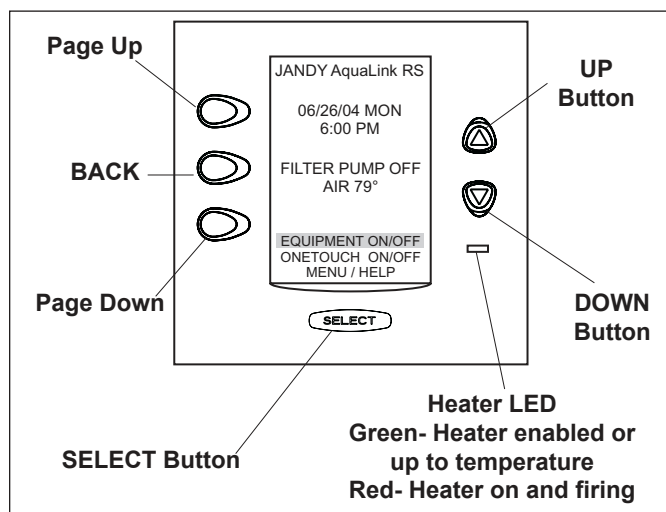

Figure 38. OneTouch™ Control Panel Buttons

4. Maintain Temperature Hours

MENU/HELP > SET TEMP > HOURS

Sets the desired time when this function will activate (default setting is 12AM to 12AM; 24 hours a day). Highlight HOURS and press SELECT. Use the UP or DOWN buttons to change the HOURS the system will maintain the set temperature.

4.3.4 Label Auxiliary Functions

MENU/HELP > SYSTEM SETUP > LABEL AUX > AUX 1-X > CHOOSE LABEL TYPE > CHOOSE LABEL

Highlight MENU/HELP and press SELECT. Highlight SYSTEM SETUP and press SELECT. Highlight LABEL AUX and press SELECT. Highlight the AUX you want to label and press SELECT. Highlight GENERAL, LIGHT, WATERFALL or CUSTOM LABEL and press SELECT. Choose a name within these categories by using the UP or DOWN button or the PAGE UP or PAGE DOWN button, press SELECT when you find the correct name. Choose CUSTOM to type in your own names.

NOTE The Auxiliary labels AIR BLOWER and FILL LINE have an automatic 30 minute runtime. To change this setting, refer to the DEVICE RUNTIME feature.
If DIP switch S1-1,2 or 3 are on, auxiliaries 1, 2 and 3 are labeled CLEANER, LOW SPEED and SPILLOVER respectively and cannot be relabeled.

4.3.5 Set Freeze Protection

MENU/HELP > SYSTEM SETUP > FREEZE PROTECT > SET TEMP VALUE > SELECT FREEZE PROTECT DEVICE

Highlight MENU/HELP and press SELECT. Highlight SYSTEM SETUP and press SELECT. Highlight FREEZE PROTECT and press SELECT. Use the UP or DOWN button to change the temperature. Once the temperature is set press the SELECT button to move to the next screen to assign freeze protection to a selected piece of equipment. Highlight a device and press SELECT. "X" means the device has been assigned.

NOTE The filter pump is always assigned to freeze protection.

4.3.6 Assign JVA's

MENU/HELP > SYSTEM SETUP > ASSIGN JVA's > SELECT JVA

Highlight MENU/HELP and press SELECT. Highlight SYSTEM SETUP and press SELECT. Highlight ASSIGN JVA and press SELECT. Highlight the JVA you wish to assign and press SELECT.

NOTE If a solar sensor is installed, the solar JVA will automatically be assigned and will be marked as USED.

4.3.7 Seasonal Adjust

MENU/HELP > SYSTEM SETUP > SEASONAL ADJ > SELECT FILTRATION/SPRINKLERS/FILL LINE/CLEANER

Highlight MENU/HELP and press SELECT. Highlight SYSTEM SETUP and press SELECT. Highlight SEASONAL ADJ and press SELECT. Use the UP/DOWN BUTTON TO choose FILTRATION, SPRINKLERS, FILL LINE, and CLEANER, then press SELECT.

NOTE FILL LINE will be displayed on the screen only if an AUX has been assigned to fill the label. CLEANER will be displayed on the screen only if DIP switch S1-1 is ON. AQUAPURE will be displayed only if a chlorine generator is attached to the system.

4.4 OneTouch™ Reset and Display Messages

4.4.1 Restarting the System

MENU/HELP > SYSTEM SETUP > CLEAR MEMORY > CONTINUE > FINAL WARNING > CONTINUE

To remove all labeling, programming, assignments and temperature settings, highlight MENU/HELP and press SELECT. Highlight SYSTEM SETUP and press SELECT. Highlight CLEAR MEMORY and press SELECT. Highlight CONTINUE and press SELECT. Use the UP or DOWN button to highlight YES or NO and press SELECT. There will be about a 15 second delay before you see the FINISHED screen. Highlight CONTINUE and press SELECT to return to the SYSTEM SETUP.

4.5 Variable Speed Pump Menu

NOTE This equipment may not be part of your system. Please check with your installer.

The VAR SPEED PUMP menu is used to select the variable speed pump type (Jandy ePump™ DC, Jandy ePump™ AC, Pentair® IntelliFlo® VF, Pentair® IntelliFlo® VS, or Pentair® IntelliPro® VS) and to select the various pump settings. To interface the IntelliPro® VS, select IntelliFlo® VS.

4.5.1 To select the Pump Type

To select a pump, highlight the desired model and press SELECT. An X will appear next to the selection. To control the IntelliFlo® VS, select the IntelliFlo® VS.

MENU/HELP > SYSTEM SETUP > VAR SPEED PUMP > SELECT MODEL > SELECT JANDY EPUMP/INTELLIFLOVS/INTFLOVF/INTELLIPRO

In SYSTEM SETUP menu, highlight VAR SPEED PUMP and press SELECT, highlight PUMP MODEL and press SELECT. Use the UP/DOWN arrow keys to highlight the desired pump, then press SELECT.

4.5.2 To set up the Pump Application

The AquaLink® can control up to 4 variable speed pumps. In the PUMP SETUP menu the user can select each pump (1-4) and configure how the pump(s) are to be used. For example if the pump is to be used for pool/spa filtration then you would select FILTRATION as the pump application. If the pump is to be used for a water feature then you would select AUX. PUMP as the pump application. The default setting is NOT INSTALLED.

COMBO	POOL SPA ONLY	DUAL EQUIPMENT
FILTRATION	FILTRATION	POOL PUMP
AUX. PUMP	AUX. PUMP	SPA PUMP
NOT INSTALLED	NOT INSTALLED	AUX. PUMP
		NOT INSTALLED

If the system is not going to control a variable speed pump then leave the application set to NOT INSTALLED. If the system is going to control a variable speed pump, then you would set the application accordingly. In the example below we are telling the system that it will be controlling one (1) variable speed pump.

MENU/HELP > SYSTEM SETUP > VSP SETTINGS > SELECT PUMP APPLICATION > SELECT PUMP1 > SELECT ITEM

In VSP SETTINGS menu, highlight PUMP APPLICATION and press SELECT, highlight PUMP1 and press SELECT. Use the UP/DOWN arrow keys to highlight the item, then press SELECT. An X will appear next to the selection.

4.5.3 To set SCALE/MIN-MAX Parameters

This screen allows the user to set a global minimum and maximum speed or flow for the indicated pump. The SCALE setting is fixed to RPM for the Jandy ePump and the Pentair® IntelliFlo® VF. The SCALE setting is fixed to GPM for the Pentair® IntelliFlo® VF.

MENU/HELP > SYSTEM SETUP > VSP SETTINGS > SELECT MIN-MAX SETTINGS > SELECT PUMP1 > CHOOSE LIMIT

In VSP SETTINGS menu, highlight MIN-MAX SETTINGS and press SELECT, highlight PUMP1 and press SELECT. Use the UP/DOWN arrow keys to highlight the desired LIMIT, then press SELECT.

4.5.4 To set Pump Speed

There are eight (8) default speed presets for each variable speed pump.

MENU/HELP > SYSTEM SETUP > VSP SETTINGS > SELECT SPEED/LABELS > SET SPEEDS > CHOOSE SPEED

In VSP SETTINGS menu, highlight SPEED/LABELS and press SELECT, highlight PUMP1 and press SELECT. Use the UP/DOWN arrow keys to highlight SET SPEED and press SELECT. Use the UP/DOWN arrow keys to highlight the desired item, then press SELECT. Use the UP/DOWN arrow keys to highlight the desired speed preset, then press SELECT. Use the UP/DOWN arrow keys to adjust the speed value, then press SELECT.

NOTE The FREEZE PROTECT speed is also set from this menu.

4.5.5 To re-label the Speed Preset

Each of the eight (8) speed presets has a label and each of those labels can be changed from the default value.

MENU/HELP > SYSTEM SETUP > VSP SETTINGS > SELECT SPEED/LABELS > LABELS SPEEDS > CHOOSE ITEM > SELECT GENERAL LABELS/CUSTOM LABELS

In the SPEED SETTINGS menu, highlight LABEL SPEEDS and press SELECT. Use the UP/DOWN arrow keys to highlight the desired PUMP, then press SELECT. Use the UP/DOWN arrow keys to highlight either GENERAL LABELS or CUSTOM LABELS and then press SELECT.

4.5.6 Default Preset Speed Labels (RS Combo and RS only)

When a pump is configured for FILTRATION, the speed presets will be labeled as shown in the table below. The presets can be relabeled.

Default Labels when Pump is configured for FILTRATION			
PRESET #	POOL/SPA COMBO	POOL/SPA ONLY	SPEED (RPM)
1	POOL	POOL	1725
2	SPA	SPEED2	2750
3	SPEED3 or CLEANER (if dip S1-1 is on)	SPEED3 or CLEANER (if dip S1-1 is on)	2750
4	SPEED4 or SPILLOVER (if dip S1-3 is on)	SPEED4	2750
5	POOL HEAT	TEMP1	2250
6	SPA HEAT	TEMP2	2250
7	SOLAR HEAT (if dip S1-7 is on) or HEATPUMP (if dip S1-7 is on) or SPEED7	SOLAR HEAT (if dip S1-7 is on) or HEATPUMP (if dip S1-7 is on) or SPEED7	2750
8	INFLOOR	INFLOOR	2750

Preset 1:

The default label for preset #1 is POOL. This label is tied to the pool filtration mode. Anytime the pool pump is supposed to turn on, this preset is selected.

Preset 2:

On combo systems the default label for preset #2 is SPA. This label is tied to the spa filtration mode, anytime the spa pump is supposed to turn on, this preset is selected.

Preset 3:

On combo systems, if dip switch S1-1 is ON, then the default label for this preset is CLEANER. Anytime the cleaner mode is turned on the pump will run at the speed setting of this preset.

On a combo system, if dip switch S1-1 is OFF, then the default label for this preset is SPEED3.

Preset 4:

If dip switch S1-3 is ON, then the default label for this preset is SPILLOVER. Anytime the spillover mode is turned on the pump will run at the speed setting of this preset.

If dip switch S1-3 is OFF, then the default label for this preset is SPEED4.

Preset 5:

On pool/spa combo systems the default label is POOL HEAT. When the pool heater is enabled the pump will run at this speed.

On pool/spa only systems the default label is TEMP1. When the pump is running and the heater set point TEMP1 is enabled, then the pump will run at this preset.

Preset 6:

On pool/spa combo systems the default label is SPA HEAT. When the system is in the SPA mode and the SPA HEATER is enabled then the pump will run at this speed.

On pool/spa only systems the default label is TEMP2. When the pump is running and the heater set point TEMP2 is enabled, then the pump will run at this preset.

Preset 7:

If the system is in the SOLAR HEAT mode or the HEAT PUMP mode then the pump will run at this preset speed. If the system is not configured for solar heat or a heat pump then the default label will be SPEED7.

Preset 8:

When the In-Floor clean mode is enabled and the pump is running, it will be running at this preset speed.

4.5.7 Default Preset Speed Labels (Dual Equipment)

When a pump is configured to be either a POOL PUMP or a SPA PUMP, the speed presets will be labeled as shown in the table below. The presets can be relabeled but the operation of the speeds may be changed by doing so.

Default Labels and Speeds when Pumps are configured as POOL PUMP and SPA PUMP (Dual Equipment Systems)			
PRESET #	POOL PUMP	SPA PUMP	SPEED
1	POOL	SPEED1	1725
2	SPEED2	SPA	2750
3	SPEED3 or CLEANER (if dip S1-1 is on)	SPEED3	2750
4	SPEED4	SPEED4	2750
5	POOL HEAT	SPEED5	2250
6	SPA HEAT	SPA HEAT	2250
7	SOLAR HEAT (if dip S1-7 is on) or HEATPUMP (if dip S2-7 is on) or SPEED7	SPEED7	2750
8	INFLOOR	SPEED8	2750

Preset 1:

On a dual equipment system when a pump is configured as a POOL PUMP, the default label for preset #1 is POOL. This label is tied to the pool filtration mode. Anytime the pool pump is supposed to turn on, this preset is selected.

On a dual equipment system when a pump is configured as a SPA PUMP, the default label for preset #1 is SPEED1.

Preset 2:

On a dual equipment system when a pump is configured as a SPA PUMP, the default label for preset #2 is SPA. This label is tied to the spa filtration mode. Anytime the spa pump is supposed to turn on, this preset is selected.

On a dual equipment system when a pump is configured as a POOL PUMP, the default label for preset #2 is SPEED2.

Preset 3:

For the pool pump, if dip switch S1-1 is ON, then the default label for this preset is CLEANER. Anytime the cleaner mode is turned on the pump will run at the speed setting of this preset. If dip switch S1-1 is OFF, then the default label for this preset is SPEED3.

For the spa pump the default label is SPEED3.

Preset 4:

The default label is SPEED4.

Preset 5:

For the pool pump the default label is POOL HEAT. When the pool heater is enabled the pump will run at this speed.

For the spa pump the default label is SPEED5.

Preset 6:

For the pool pump the default label is SPEED6.

For the spa pump the default label is SPA HEAT. When the spa heater is enabled the pump will run at this speed.

Preset 7:

For the pool pump, if the system is in the SOLAR HEAT mode or the HEAT PUMP mode then the pump will run at this preset speed. If the system is not configured for solar heat or a heat pump then the default label will be SPEED7.

For the spa pump the default label is SPEED7.

Preset 8:

For the pool pump, when the In-Floor clean mode is enabled and the pump is running, it will be running at this preset speed.

For the spa pump the default label is SPEED8.

4.6 All Button and OneTouch™ System Defaults and General Modes

Default Temperature (Pool/Spa Combination)	Default Pool Temp = 80°F Default Spa Temp = 102°F
Default Temperature (Pool/Spa Only)	Default TEMP1 = 80°F Default TEMP2 = 60°F
Default Spa Side Switch Settings	Button 1 = Spa (Filter Pump for pool/spa only models) Button 2 = Spa Heater (Temp1 for pool/spa only models) Button 3 = AUX1 Button 4 = AUX2
Default Freeze Protection Settings	FILTER PUMP: freeze protection ON. ALL OTHER EQUIPMENT, freeze protection OFF.
NOTE If you select SPA to be freeze protected, water circulation will switch between pool and spa every 30 minutes during freezing conditions once freeze mode is active.	

4.6.1 Power Center Service Switch

AUTO Mode (automatic)

1. The control panel has complete control of all functions.
2. All programmed settings will operate.
3. All safety delays and equipment protection interlocks are operational.

SERVICE Mode

1. The power center has complete control of all functions.
2. Service mode must be turned on/off at the power center.
3. No programmed settings will work.

CAUTION

In service mode, the safety interlocks for equipment protection are overridden.

TIMEOUT Mode

1. The power center has complete control for three (3) hours.
2. After three (3) hours the system will return to AUTO mode.
3. Programmed on/off times will be overridden during the three (3) hours.
4. After the three (3) hour "time out", the system will resume any programmed items that were overridden.

4.6.2 Changing the Chlorine Production Settings at the Equipment

The AquaPure® and AquaLink® RS now have two-way communication. The AquaLink® RS power center will read settings or modifications made from the AquaPure service panel. This feature is available with AquaPure® front PCB firmware version 11230A05 or later. Your firmware revision number can be found on the back of the front AquaPure® PCB.

Changing Chlorine Production Percentage Rate

1. At the AquaLink® RS power center:
 - A. The AquaLink® RS control system must be set to service mode before you can change the chlorine production levels from the AquaPure® service panel. Press the mode select button to move the AquaLink® RS from auto mode into service mode. The indicator light located next to the service will turn ON.
 - B. Press the valve select button to choose either pool mode to change pool chlorine production, or spa mode to change spa chlorine production.
 - C. Press the filter pump button to turn on the pump and apply power to the AquaPure® system.

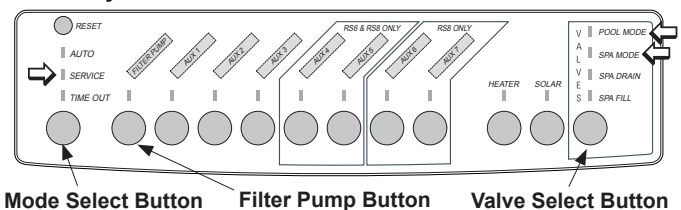

Mode Select Button Filter Pump Button Valve Select Button



Press to increase or decrease % Chlorine Production

2. At the AquaPure® Service Panel:
 - A. Press the UP/DOWN arrow buttons on the AquaPure® service panel to increase or decrease chlorine production rate for either the pool or spa.
When the desired value for chlorine production is set from the AquaPure® service panel, return to the AquaLink® RS power center.
3. At the AquaLink® RS Power Center:
 - A. Press the mode select button to put the AquaLink® RS in time out mode.
 - B. Press the mode select button again to place it back into auto mode.

NOTE: THE POWER CENTER MUST BE IN POOL MODE TO CHANGE THE AQUAPURE POOL SETTING; IT MUST BE IN SPA MODE TO CHANGE THE AQUAPURE SPA SETTING. USE THE VALVE SELECT BUTTON TO SWITCH BETWEEN THE TWO MODES. SYSTEM MUST BE CYCLED THROUGH SERVICE, TIME OUT THEN BACK TO AUTO TO ACCEPT THE POOL SETTINGS VS. SPA SETTING.

4.6.3 Power Interruption

In the event there is a power interruption, and the AquaLink RS system is in service or time Out mode, the system will default to auto. In previous firmware versions, the system would default to last mode of operation.

ATTENTION

Special Note to Startup Person: The AquaLink® RS allows two (2) options for operating the pool equipment on the first day of operation:

- Option #1** Once all programming of equipment is completed, the AquaLink® RS will automatically review all programs and turn on any equipment which is programmed to be on.
- Option #2** To operate the filter pump or cleaner continually for the first day, leave the power center service button in AUTO mode. At the indoor control panel, press the filter pump or cleaner buttons for the equipment you want to run. The equipment that is activated will run continuously, ignoring the first programmed off time, and will turn off at the programmed off time for the next day (only if a program has been entered).

4.7 All Button Menu Flow Chart

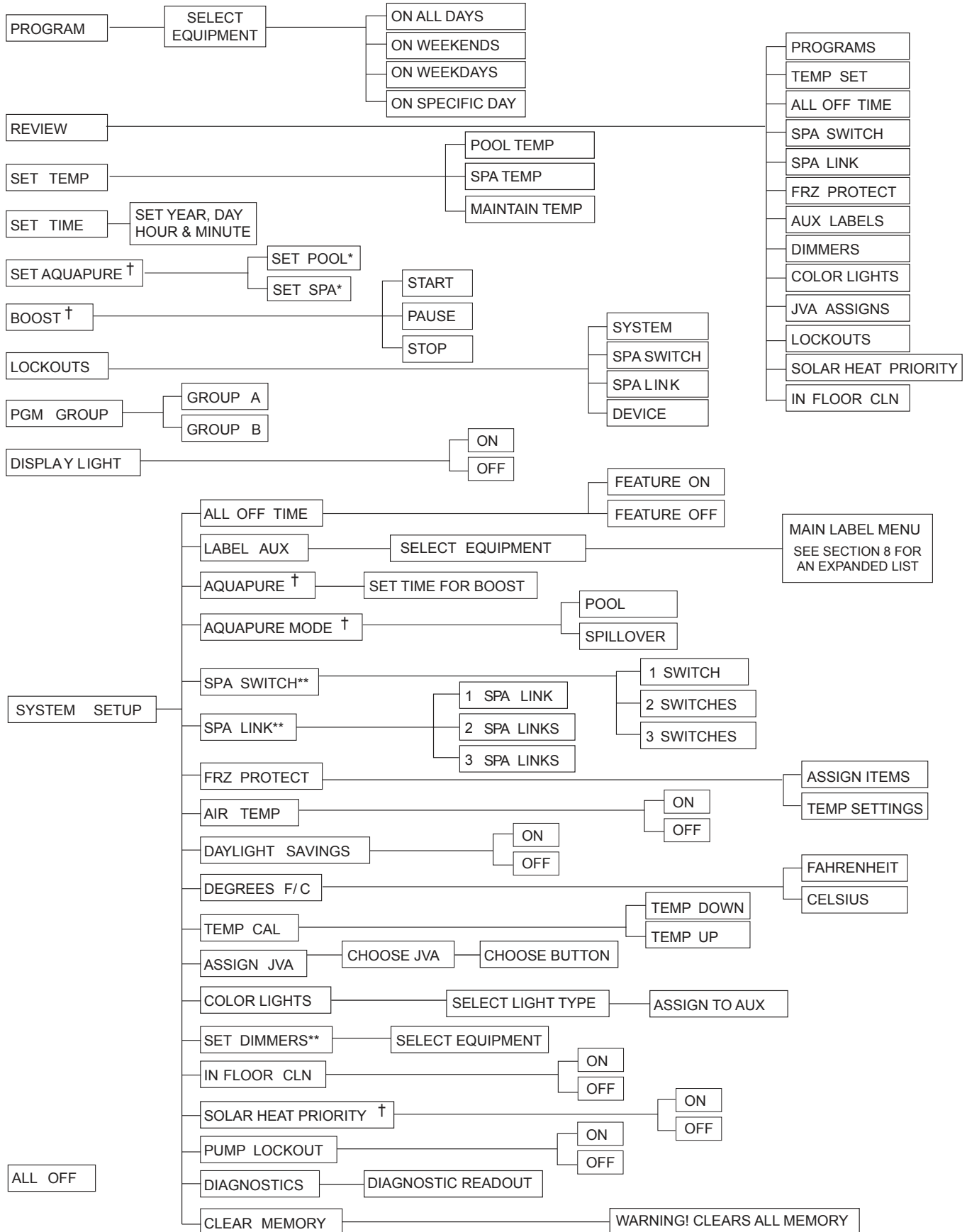

† Items Seen Only With Optional Equipment
 * Items Seen Only In Revision "M"
 ** Not Available on Export Models

4.8 OneTouch™ Menu Flow Chart

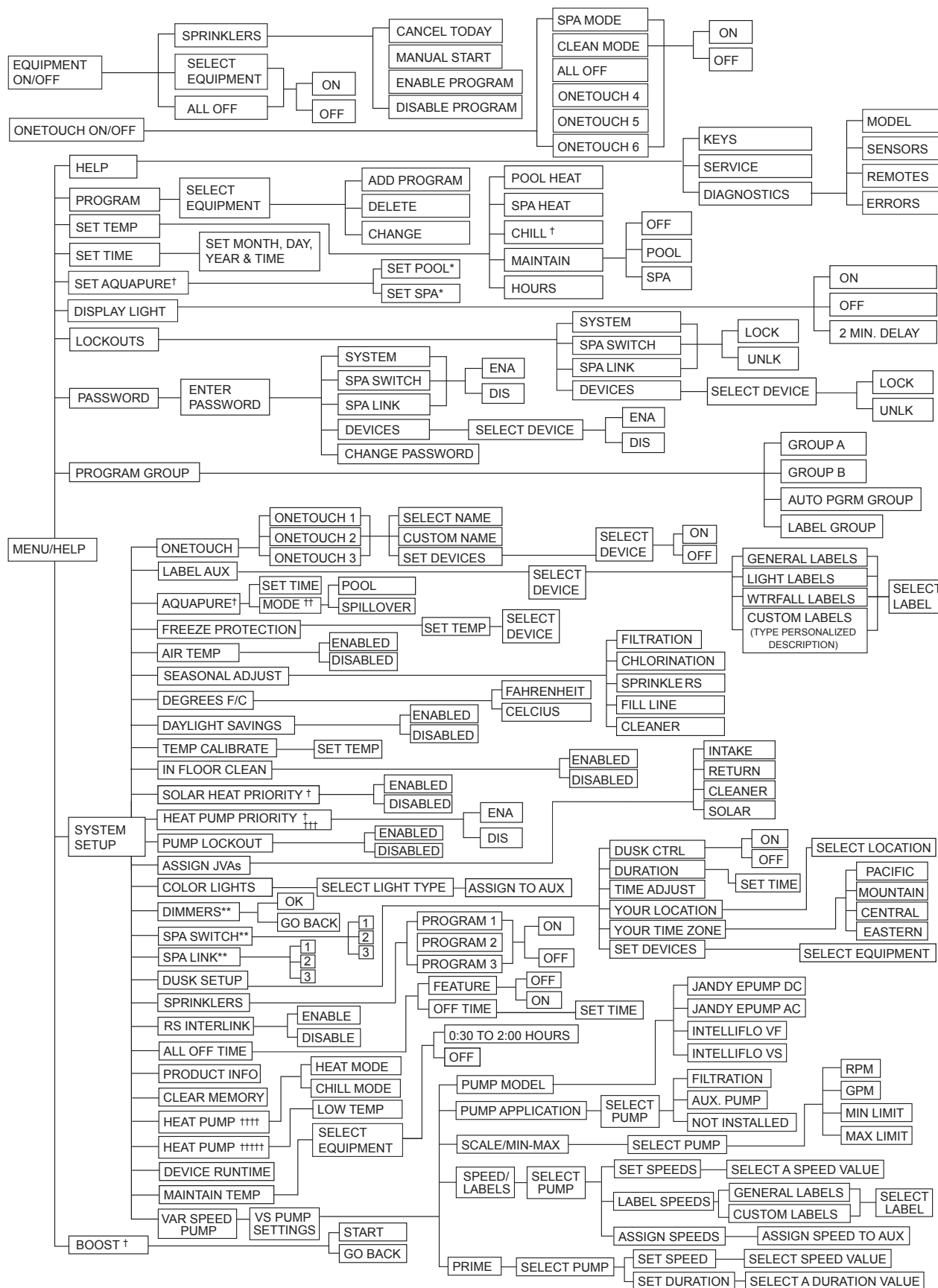

† Items seen only with optional equipment
 †† Mode only displayed when DIP switch S1-3 is set to ON
 ††† DIP switch S2-1 must be ON. See differences between heat pumps controlled via RS485 or solar pump relay
 †††† Heat pump is controlled via the solar pump relay
 ††††† Heat pump is controlled via the RS485
 * Items seen only in Revision "N" or later
 ** Not Available on Export Models

Section 5. Troubleshooting

5.1 All Button and OneTouch™ Quick Troubleshooting Guide

Symptom	Problem	Possible Solution
Power center override switches operate when in service or time out mode, but the control panel is completely dead (no lights on, no display).	Power supply problem.	Check connection of the outside two wires (red & green) of the four conductor cable. If wired correctly, check the voltage between these two wires. Voltage for an All button system should be 7+ VDC and for a OneTouch system, 8+ VDC (use the higher voltage for a mixed system).
All LEDs are on at the control panel and the part # and revision letter of the control panel software are displayed. The override switches at the power center operate as they should.	Control panel is not communicating with the power center PCB.	Check the two center wires (black & yellow) of the four conductor cable. Also check the installation of the CPU Board on the power center PCB. If the PPD is not seated correctly the system will not communicate.
All LEDs are on at the control panel and the part # and revision letter are displayed, but override switches at the power center do not operate at all.	<ol style="list-style-type: none"> 1. Damaged or improperly installed CPU Board. 2. Damaged power center PCB. 	<ol style="list-style-type: none"> 1. Check alignment of the CPU Board. 2. If CPU Board is installed correctly, replace the power center PCB.
Some buttons do not operate from the control panel, nor from the power center override switches.	Wrong CPU Board chip installed at the power center PCB.	Check part number and revision letter by pressing the reset button at the control panel. The second part number and revision letter displayed is for the CPU Board indicating which model.
System locked up.	Microprocessor locked.	Turn off power to the system and turn back on.
Programs do not run at the correct time.	AquaLink® does not display correct time and date.	At the control panel set correct time and date.
One button on the Four Function Remote or SpaLink® RS does not operate.	Check programming first. If the Four Function Remote or SpaLink® RS is programmed correctly, the button may be shorted.	Replace the Four Function Remote or SpaLink® RS. Use MENU, REVIEW, SPA SWITCH (or SPA LINK) to check programming.
Pool cleaner booster pump turns on without the filter pump being on, and can run with the spa on.	System is not recognizing DIP switch S1-1 is on. Note: before turning on any DIP switches, first turn off all equipment.	Turn off all equipment buttons, then turn off power to the system, finally turn off, then on, DIP switch S1-1. Turn on power and test system.

Symptom	Problem	Possible Solution
Model is one of the AquaLink® RS Dual Equipment, message scrolls "ADJUSTABLE FREEZE SENSOR NOT INSTALLED". System comes on at times that are not programmed.	Normal operation when a Dual Equipment AquaLink® RS is controlling a solar system and an adjustable freeze sensor is not installed.	Either install the adjustable freeze sensor, or wait 24 hours and this message will go away.
System comes on at times that are not programmed.	Phantom programs.	At the control panel press MENU, then scroll to REVIEW. Make note of all programs (the Four Function Remote setting, labels, and temperature settings) then turn off all DIP switches and go to the control panel. CLEAR MEMORY, reprogram and try system again.
Heater will not fire. Heater LED will not light in "Service Mode".	Water temperature sensor not installed or defective.	Check water temperature sensor.

5.2 Wireless OneTouch™ Quick Troubleshooting Guide

The Wireless AquaLink® RS will stop communicating anytime interference (such as from a microwave oven or other 2.4 GHz devices) prevents a valid signal transmission. When communication is lost the control panel will lock on "Model Number" until a good link is again achieved, usually within a few seconds. If communication is not reestablished within a few seconds or this happens often, use the troubleshooting information in the following table for suggestions.

NOTE On the battery wireless, the display screen will go into "Sleep Mode" after 60 seconds. That is, if a button has not been pressed within 60 seconds, the screen will go blank. Press any button on the control panel to turn the display on again.

Symptom	Problem	Possible Solution
RS system operation is slow or display is erratic.	Older firmware installed.	Replace socketed chip in OneTouch printed circuit board with Firmware B11 or newer.
LCD screen display stays on "Firmware B11" (or later).	No communication between indoor control panel and power center J-box.	<ol style="list-style-type: none"> Confirm DIP switch settings on both the indoor control panel transceiver and power center transceiver are as follows: <ul style="list-style-type: none"> DIPs 1-7 are set identical DIP 8 is ON at power center J-box PCB DIP 8 is OFF at control panel transceiver PCB At the power center J-box transceiver board, press the SW1 setup button and confirm that the green LED flashes approximately 10 times.

Symptom (continued)	Problem	Possible Solution
<p>LCD screen display stays on "Firmware B11" (or later).</p>	<p>No communication between indoor Control Panel and Power Center J-box.</p>	<ol style="list-style-type: none"> 3. Repeat Step 2 for the Indoor Desktop Control Panel. 4. Recheck the Indoor Desktop Control Panel for proper performance. 5. If there is no communication yet, check LED's at the Power Center J-box Transceiver PCB. <ul style="list-style-type: none"> • Red LED must be lit to indicate power. If red LED is not lit check 4-conductor wire connection to the red, 4-pin terminal bar at the Power Center. • Amber middle LED must blink continually. If not blinking, transceiver needs to be replaced with part #8114 or #8241 depending on the manufacture date. If amber LED is blinking at Power Center J-box Transceiver, go to the Indoor Control Panel. 6. If still no communication, check LED's at the Indoor Control Panel Transceiver PCB. <ul style="list-style-type: none"> • At the Indoor Control Panel Transceiver PCB, confirm that the red LED is on indicating power. If red LED is not lit, confirm unit is plugged into wall socket and 4-conductor wires are connected to the red, 4-pin terminal bar on the Indoor Control Panel PCB. • If green LED is lit, indicates correct data is being received from the Power Center. If green LED is not lit, there is an obstruction of the RF signal caused by metal barriers. • Test Indoor Control Panel in close proximity to Power Center. If the unit tests okay, the placement of one or both transceivers needs to be moved for proper communication. • If green LED is lit, verify that the middle amber LED is blinking continuously which indicates data transmission from the Indoor Control Panel to the Power Center. • Go to the Power Center and verify that the green LED is lit, indicating correct data being received from the Indoor Control Panel. • This completes verification of the data transmission loop from the Power Center to the Indoor Control Panel and back. 7. Wireless Control Panel does not revert to sleep mode after 30 seconds, install OneTouch PCB Firmware B11 or newer.

Section 6. Power Center Wiring Diagram for Combos and Onlys

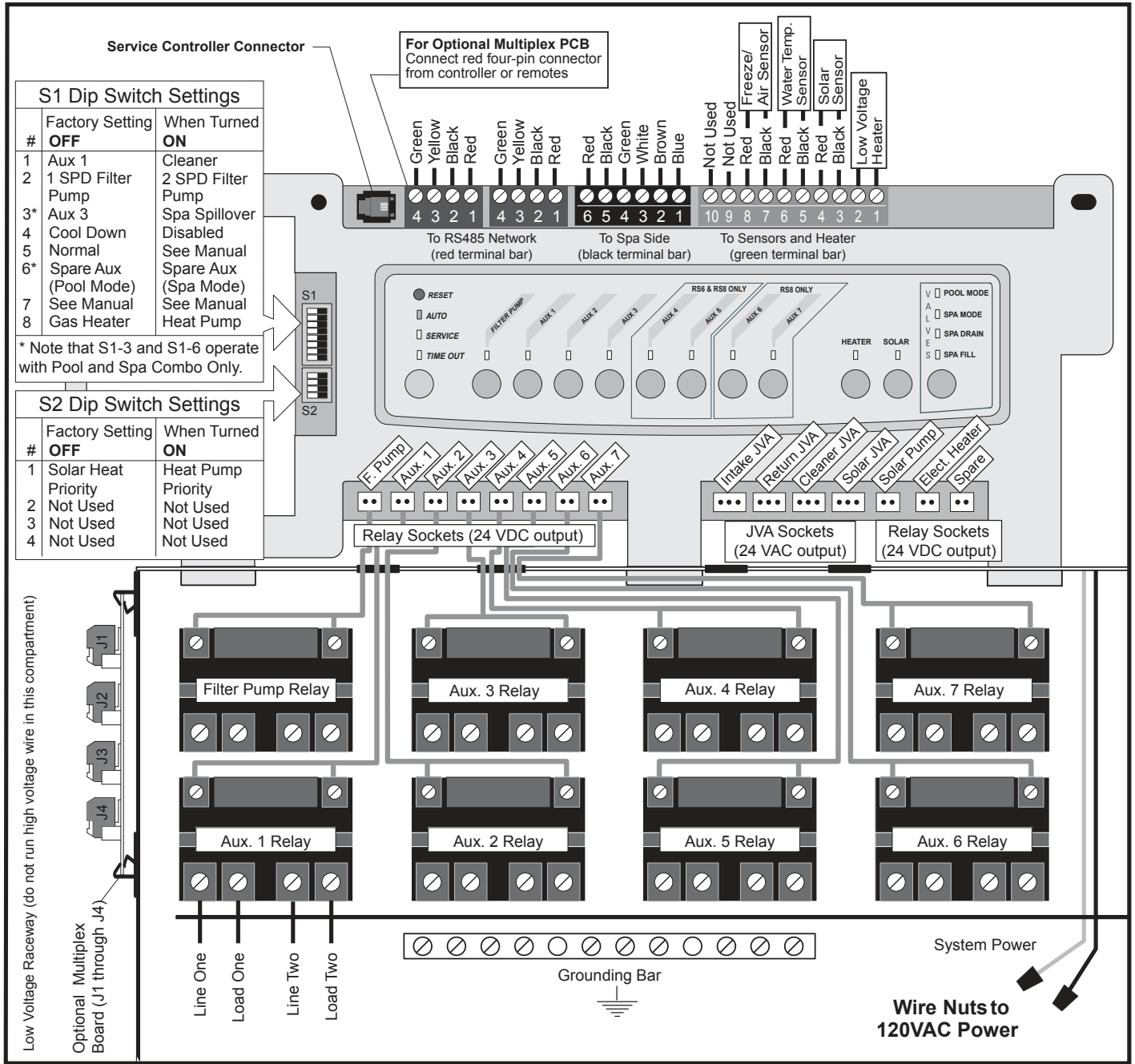

Section 7. Power Center PCB DIP Switch Settings

7.1 DIP Switch Functions

S1 DIP #1 ON- AUX 1 Controls Pool Cleaner

If you installed a booster pump for a pool cleaner, the relay coil for the booster pump must be plugged into the AUX 1 relay socket. If a non-booster pump cleaner is installed, plug the JVA into the cleaner JVA socket. Turn ON DIP Switch #1.

- Main filter pump turns on whenever cleaner turns on.
- Cleaner will not turn on until filter pump has been on for three (3) minutes (to ensure priming of system).
- Cleaner turns off when water circulation is to spa.
- Cleaner turns off when spa spillover feature is activated.
- Cleaner turns off for three (3) minutes when solar is activated (to ensure air is purged from the system).
- AquaLink® RS control panel display reads "CLEANER" rather than "AUX 1".

S1 DIP #2 ON- AUX 2 Controls Low Speed of Filter Pump

Turn this switch ON if you want to control both speeds of a two-speed filter pump. With this switch on, the filter pump button on the AquaLink® RS control panel will control high speed and the AUX 2 button will control low speed.

IMPORTANT You must also install a Jandy two-speed relay.

S1 DIP #3 ON- AUX 3 Controls Spa Spillover (Operates with Pool/Spa Combination)

Turn this switch ON, and when the AUX 3 button on the AquaLink® RS control panel (or spa side switch) is pressed, the return valve actuator will rotate to spa circulation. Because the intake valve actuator does not rotate, the spa will fill with water and overflow into the pool.

NOTE Leave AUX 3 relay socket empty.

S1 DIP #4 ON- Heater Cool Down Disabled

Turn this switch ON to disable the heater cool down safety feature on the AquaLink® RS.

CAUTION

Turn this DIP Switch ON only if you are using an electric heater or a heat pump that does not retain residual heat. If you are turning this switch ON for service purposes, be sure to turn it back off.

S1 DIP #5 ON- Factory Use Only

This switch is used for calibration by Jandy certified technicians only. Please leave this switch in the OFF position.

S1 DIP #6 ON

Change spare AUX to activate when filter pump is on and system is in spa mode (pool/spa combination units only). Spare AUX socket is on the front side of the power center PCB.

S1 DIP #7 ON- Not Used

This switch only applies to DUAL EQUIPMENT systems. When OFF a separate heater is used for the pool and spa. When ON the pool and spa share the same heater.

S1 DIP #8 ON- Heat Pump Instead of Gas Heater

Turn this switch ON if you have installed a heat pump instead of a gas heater. After thermostat setting has been reached, heater will remain OFF for 5 minutes.

S2 DIP #1 ON- Heat Pump Priority

This switch is used for configuring solar priority or heat pump priority. Set this switch to ON if heat pump priority will be used. Set this switch to OFF if solar priority is to be used.

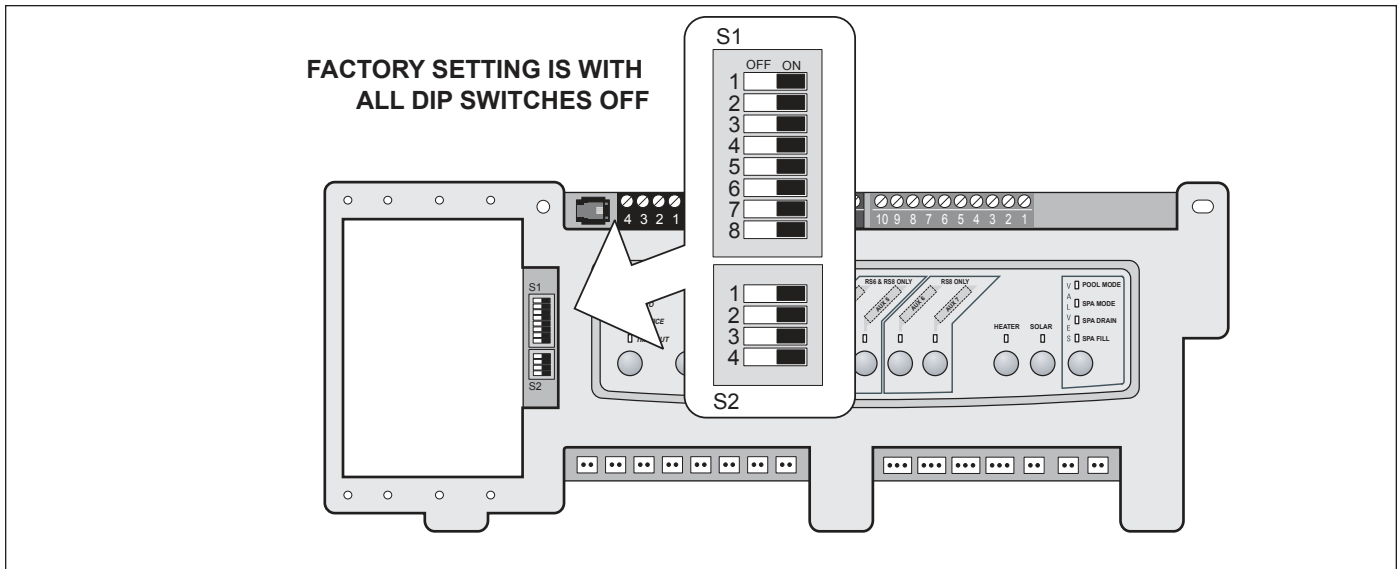

7.2 DIP Switch Settings for Pool and Spa Combination

S1 DIP Switch #	OFF	ON
1	AUX1= any equipment	AUX1= Pool Cleaner
2	AUX2= any equipment	AUX2= Low Speed for a two-speed filter pump. Filter pump circuit becomes High Speed.
3	AUX3= any equipment	AUX3= Spa Spillover effect- Combination controls only.
4	Heater cool down operates.	Heater cool down disabled.
5	Normal operation	Factory adjustment- when this switch is on, temperature delays are eliminated and solar temperature is displayed. Do not leave this switch in the ON position.
6	Spare Aux activates with Filter Pump when Spa OFF.	No change on Revision "HH" or older PPD. With revision "I" or newer, Spare AUX operation is reversed.
7	Spare	No change on Combination or Only Controls.
8	After thermostat setting has been reached, heater will remain OFF for three (3) minutes.	Heat Pump installed; after thermostat setting has been reached, heater will remain OFF for five (5) minutes.

S2 DIP Switch #	OFF	ON
1	The AquaLink® RS will be able to control a Solar Heating system (If a solar sensor is connected to the solar sensor input).	The AquaLink® RS will be able to control a Heat Pump. (The AquaLink® RS will not be able to control a Solar Heating system.)
2		NOT USED
3		NOT USED
4		NOT USED

7.3 DIP Switch Settings for Pool or Spa Only

S1 DIP Switch #	OFF	ON
1	AUX1= any equipment	AUX1= Pool Cleaner
2	AUX2= any equipment	AUX2= Low Speed for a two-speed filter pump. Filter pump circuit becomes High Speed.
3	AUX3= any equipment	No change
4	Heater cool down operates.	Heater cool down disabled.
5	Normal operation	Factory adjustment- when this switch is on, temperature delays are eliminated and solar temperature is displayed. <i>Do not leave this switch in the ON position.</i>
6	Spare	No change
7	Spare	No change
8	After thermostat setting has been reached, heater will remain OFF for 3 minutes.	Heat Pump installed; after thermostat setting has been reached, heater will remain OFF for 5 minutes.
S2 DIP Switch #	OFF	ON
1	The AquaLink® RS will be able to control a Solar Heating system (If a solar sensor is connected to the solar sensor input).	The AquaLink® RS will be able to control a Heat Pump. (The AquaLink® RS will not be able to control a Solar Heating system.)
2	NOT USED	
3	NOT USED	
4	NOT USED	

7.4 DIP Switch Settings for Heat Pump Installation

This table shows how to configure the system for SOLAR PRIORITY or HEAT PUMP PRIORITY.

DIP S2-1	GREEN 10-PIN TERMINAL BAR	RS485 HEAT PUMP	DESCRIPTION
OFF	No sensor installed	Not connected	In this configuration there is no Solar Heating and no Heat Pump. Extra AUX is available.
OFF	Sensor installed	Not connected	In this configuration there is Solar Heating and there is Solar Priority. There is no Heat Pump.
OFF	Sensor installed	Connected	In this configuration there is Solar Heating and there is Solar Priority. There is Heat Pump. There is Heat Pump Priority.
ON	No sensor installed	Not connected	In this configuration there is no Solar Heating. There is a mechanically connected Heat Pump. There is Heat Pump Priority (a limited implementation).
ON	Sensor installed	Not connected	In this configuration there is no Solar Heating. There is a mechanically connected Heat Pump. There is Heat Pump Priority (full implementation).
ON	Sensor installed	Connected	In this configuration there is no Solar Heating. There is an RS485 controlled Heat Pump. There is Heat Pump Priority.

Section 8. General, Water Feature and Light Aux Labels

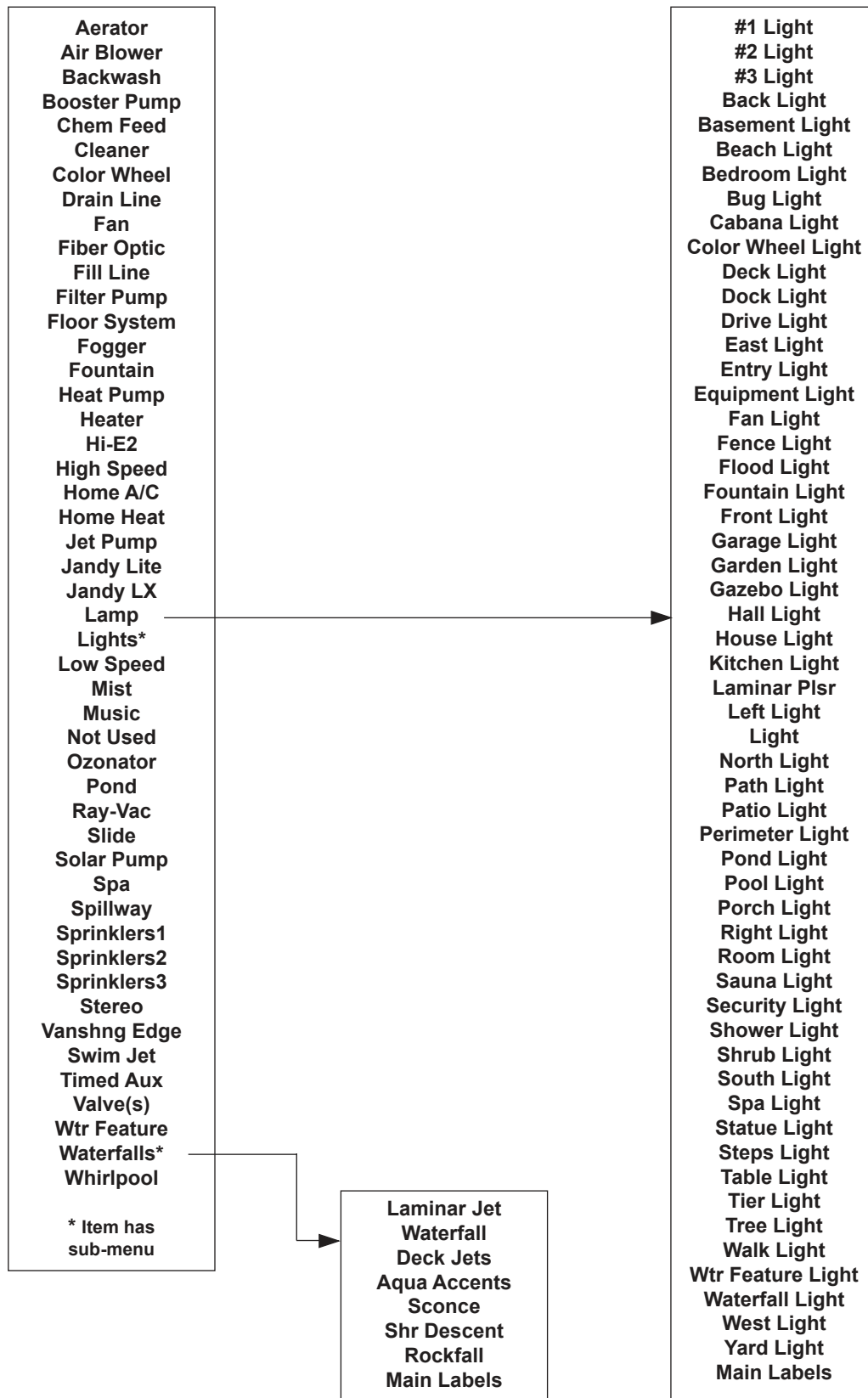

LIMITED WARRANTY

Thank you for purchasing Jandy® pool and spa products. Jandy Pool Products, Inc. warrants all parts to be free from manufacturing defects in materials and workmanship for a period of one (1) year from the date of retail purchase, with the following exceptions:

- AquaLink® RS units installed with Jandy Surge Protection Kits will be covered for two (2) years.
- Never Lube® valves are warranted for the life of the pool and/or spa on which they were originally installed.
- AquaPure® Electronic Chlorine Generator Electrolytic Cells carry a five (5) year limited warranty on a prorated basis.
- Heat pumps are covered for two (2) years. There is a lifetime warranty on titanium tubing.
- The heat pump compressor is covered for five (5) years.

This warranty is limited to the first retail purchaser, is not transferable, and does not apply to products that have been moved from their original installation sites. The liability of Jandy Pool Products, Inc. shall not exceed the repair or replacement of defective parts and does not include any costs for labor to remove and reinstall the defective part, transportation to or from the factory, or any other materials required to make the repair. Refrigerant or other expendables are not covered by the warranty. This warranty does not cover failures or malfunctions resulting from the following:

1. Failure to properly install, operate, or maintain the product(s) in accordance with our published Installation, Operation and Maintenance Manuals, which are provided with the product(s).
2. The workmanship of any installer of the product(s).
3. Not maintaining a proper chemical balance in your pool and/or spa [pH levels between 7.2 and 7.8, with ideal ranges being between 7.4 and 7.6, Total Alkalinity (TA) between 80 to 120 ppm, Total Dissolved Solids (TDS) less than 2000, not including salt ppm].
4. Abuse, alteration, accident, fire, flood, lightning, rodents, insects, negligence, or acts of God.
5. Scaling, freezing, or other conditions causing inadequate water circulation.
6. Operating the product(s) at water flow rates outside the published minimum and maximum specifications.
7. Use of non-factory authorized parts or accessories in conjunction with the product(s).
8. Chemical contamination of combustion air or improper use of sanitizing chemicals, such as introducing sanitizing chemicals upstream of the heater and cleaner hose or through the skimmer.
9. Overheating; incorrect wire runs; improper electrical supply; collateral damage caused by failure of O-rings, DE grids, or cartridge elements; or damage caused by running the pump with insufficient quantities of water.

LIMITATION OF LIABILITY:

This is the only warranty given by Jandy Pool Products, Inc. No one is authorized to make any other warranties on behalf of Jandy Pool Products, Inc. **THIS WARRANTY IS IN LIEU OF ALL OTHER WARRANTIES, EXPRESSED OR IMPLIED, INCLUDING, BUT NOT LIMITED TO, ANY IMPLIED WARRANTIES OF FITNESS FOR A PARTICULAR PURPOSE AND MERCHANTABILITY. JANDY POOL PRODUCTS, INC. EXPRESSLY DISCLAIMS AND EXCLUDES ANY LIABILITY FOR CONSEQUENTIAL, INCIDENTAL, INDIRECT, OR PUNITIVE DAMAGES FOR BREACH OF ANY EXPRESSED OR IMPLIED WARRANTY.** This warranty gives you specific legal rights. You may also have other rights that vary by state or province.

WARRANTY CLAIMS:

For prompt warranty consideration, contact your dealer and provide the following information: proof of purchase, model number, serial number, and date of installation. The installer will contact the factory to obtain instructions regarding the claim and to determine the location of the nearest designated service center. If the dealer is not available, you can locate a service center in your area by visiting www.jandy.com or by calling our technical support department at 1.707.776.8200, extension 260. All returned parts must have a Returned Material Authorization number to be evaluated under the terms of this warranty.

